

A New Simple Single Phase AC-AC Switching Voltage Regulator Cum Power Conditioner

S. Sonar¹ T. Maity²

Abstract—A new very simple single phase ac-ac voltage regulator based on LC network is proposed here that compensates wide range supply voltage variations. This has the capability of both buck and boost the input source voltage level without any change of phase angle. The number of components used in the converter circuit is minimum and smooth output waveform can be achieved without any additional filter. The proposed system employs two bi-directional switches having high frequency pulse width modulation (PWM) and one LC network along with a simple closed loop control. The source voltage level can be sensed and divided by the desired output value to find the instantaneous value of gain, which mathematically calculates the possible duty ratio of PWM switching signal based on the open loop characteristics of the converter. High speed IGBTs are used as bi-directional switch of the ac-ac converter and the circuit ultimately can easily and steadily maintain regulated voltage supply across the load terminals. The whole system operating principle and analysis are presented in this paper. Simulation and experimental results confirm the quality steady output both in dynamic and steady state conditions.

Keywords—LC network, pulse width modulation, ac regulator, power conditioner.

I. INTRODUCTION

Different types of power quality problems exist in our power system like transients, voltage sags/ surges, harmonics etc. Among these problems, short term voltage fluctuations i.e. voltage surge and voltage sags constitute the major disturbances and have the largest negative impact on industrial productivity as well as in rural electrification. There are also many sensitive load devices today which can not withstand this voltage fluctuation and cause frequent failures. Most voltage variations are due to different power circuit faults, line losses or major changes of load current. Many devices have been developed to perform the role of regulating, conditioning, purifying incoming power with adequate power quality standard.

Ac to ac power conversion is the most popular way to generate quality ac power after the introduction of power electronics. There are two major areas where ac-ac power conversion is necessary. One is the popular v-f ac drive where output voltage and output frequency both are required to be variable. The most popular topologies for that application are indirect ac-ac converters with a dc link [1]–[3], matrix converters [4],[5]. However, in another case only voltage variation or regulation is needed with no change in frequency, the direct PWM ac-ac converters are used which perform as ac choppers or power line conditioners.

The paper first received 23 Sep 2012 and in revised form 18 Dec 2012.

Digital Ref: APEJ-2012-12-407

¹ Department of Electrical Engineering, Indian School of Mines, Dhanbad 826004, India. E-mail: santosh_recd@rediffmail.com

² Department of Electrical Engineering, Indian School of Mines, Dhanbad 826004, India. E-mail: tanmoy_maity@yahoo.com

They have some advantages like the provision of better power factor, efficiency, low harmonic current in line, ease of control and smaller size and lower cost. Moreover it is a single-stage conversion with simple topology. The traditional direct PWM ac-ac converters are implemented by bi-directional ac thyristor power controllers or triac, which use phase angle or integral cycle control of the ac supply to obtain the desired output voltage. But, they have some disadvantages, such as high total harmonic distortion (THD) in the source current, low power factor, and poor power transfer efficiency. Moreover, they don't have any facility of boosting the input voltage without using transformer in the circuit. Recently, Z-source converters applied to ac-ac conversion have been proposed in [6],[7]. In [6], the concept of z-source ac to ac converter is proposed where two switches (either bi-directional or single-directional with dc rectifier) are turned on and off alternately. The Z-network consists of two inductors and two capacitors. The circuit proposed is only meant for open loop and no control circuit is proposed to generate PWM signals with variable duty ratio. Also, the topology requires filters at the load terminal to get the smooth ac output. The possibilities of different topologies for ac-ac conversion are reviewed in [8] without detailed discussions.

In this paper, the single phase voltage-fed LC network power converter is presented with a different kind of switch topology. The proposed LC network consists of single capacitor and single inductor which works as energy storage as well as filtering element in turns reduces the complexity of the system. It does not require any additional components for filtering the output. The converter is fitted with a feed-forward control which will run the converter as an ac regulator under wide range input variation condition. High frequency switching of two set of bi-directional switches through proper control of duty ratio, can provide variable boost factor and hence the required stable single phase ac voltage.

II. PROPOSED CIRCUIT MODEL

The overall proposed closed loop system based on single-phase LC network ac-ac converter is shown as block diagram in Fig.1. The main ac to ac converter block consists of the ac single phase source, an LC-network and two bi-directional switches. The load may be resistive or inductive. The LC-network, a combination of one inductor and one capacitor as shown in Fig. 1(a), is the main elements here which store or release energy accordingly to drive the circuit as a perfect regulator.

Each of the bidirectional switches $S1$ and $S2$ used, is having configuration as shown in Fig. 1(b). Here, a bi-directional switch is realized as a set of two IGBTs connected in common emitter mode back to back with two

diodes. The diodes are included to provide the reverse blocking capability. Switches $S1$, $S2$ are able to block voltage and to conduct current in both directions. The $S1$ and $S2$ are provided PWM high frequency switching pulses, complement to each other. The selection of higher value of switching frequency for PWM signal is expected to keep the value of inductor and capacitor of LC network low.

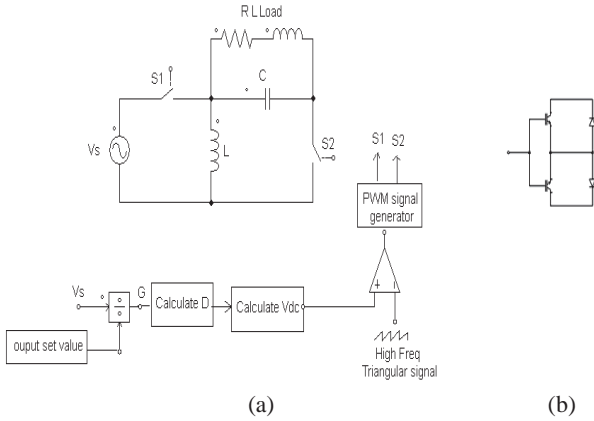

Fig. 1: (a)Block diagram of the proposed closed loop system. (b) Bidirectional switch configuration

When the switch $S1$ is on, the inductor L stores electromagnetic energy from the ac source. Also, at the same time switch $S2$ is off and the capacitor C discharges through the load. This phase is shown as an equivalent circuit in Fig. 2(a). Again, when the switch $S1$ is off and $S2$ is on, then the stored energy of the inductor supplies current to charge the capacitor C as well as provide load current through switch $S2$. The equivalent circuit for this stage is shown in Fig.2 (b).

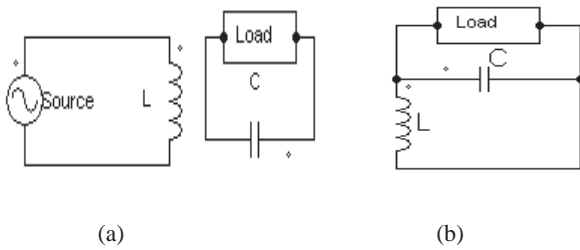

Fig 2: Equivalent circuit (a) when switch $S1$ is on and $S2$ is off (b) when switch $S1$ is off and $S2$ is on

Given that the switch $S1$ is in the conduction state for an interval of T_{on} and in non-conduction state for an interval of T_{off} during a switching cycle T . From the equivalent circuit of Fig. 2(a) one has during T_{on}

$$v_L = V_s \tag{1}$$

where V_s =source voltage. v_L =voltage across the inductor L .

Now considering the interval T_{off} , from the equivalent circuit Fig. 2(b) one has

$$v_L = V_o \tag{2}$$

where V_o = voltage output across load.

The average voltage of the inductor over one switching period (T) should be zero in the steady state, from (1) and (2) thus we have

$$V = \bar{v}_L = \frac{V_s \times T_{on} - V_o \times T_{off}}{T} = 0$$

So,

$$\frac{V_o}{V_s} = \frac{T_{on}}{T_{off}} = \frac{D}{1-D} = G \tag{3}$$

where D =duty ratio of the PWM signal applied to the switch $S1$ and G =open loop gain of the proposed converter. Voltage gain derived in (3) shows the buck-boost property of the ac-ac converter. The open loop characteristic of the converter is plotted in Fig. 3.

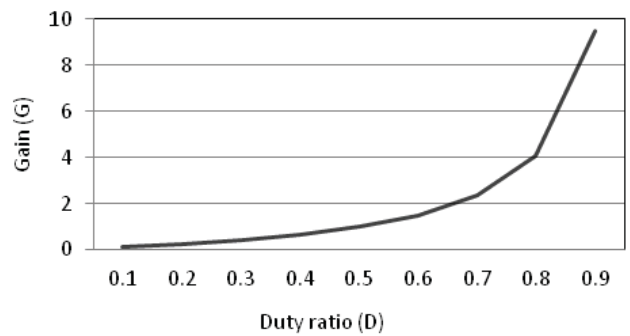

Fig. 3: Gain vs duty ratio graph of buck-boost converter.

Now based on this characteristics, a closed loop system is developed that can work as a perfect voltage regulator under variable source voltage condition. The control circuit proposed to work in feed-forward mode, senses the source voltage continuously through a voltage sensor. The desired output voltage rms value is the reference value here, which is divided by the source voltage to calculate mathematically the instantaneous value of gain, which calculates the possible duty ratio of PWM switching signal based on the open loop characteristics of the converter. For the generation of PWM signal, a triangular signal of desired switching frequency and dc control signal v_{dc} are compared in a comparator. The v_{dc} is generated in the process as explained below and shown in Fig. 4.

From the property of similarity between the two triangles, the following can be obtained from the Fig. 4

$$h / T = (h - v_{dc}) / T_{on} \tag{4}$$

$$h - v_{dc} = (h / T) T_{on} \tag{5}$$

As the peak value of the triangular signal selected is unity,

$$v_{dc} = 1 - (T_{on} / T) \tag{6}$$

$$v_{dc} = 1 - D \tag{7}$$

With the help of simple mathematical blocks the value of control signal v_{dc} is calculated which is then sent to comparator to generate the corresponding PWM output. The PWM output is fed to bi-directional switch $S1$ directly and the complement of the signal to switch $S2$.

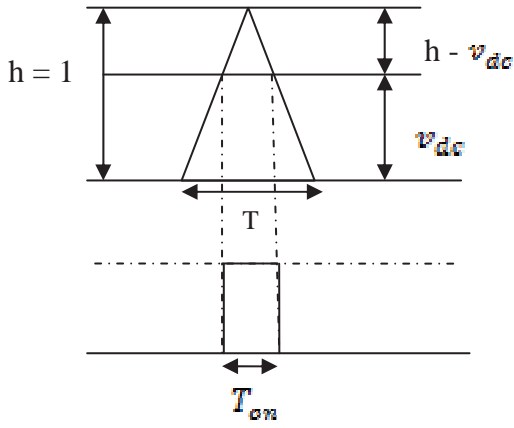

Fig. 4: Pulse width modulated signal generation

III. RESULTS AND ANALYSIS

The single phase ac-ac voltage regulator has the capability to buck/boost the source voltage, and this can be used to overcome steady state or transient voltage fluctuation even voltage sag or voltage rise in power system. Simulation is carried out in MATLAB-SIMULINK environment for the proposed control system. The L - C network is selected after various observations on open loop characteristics and chosen for this simulation as $C=10\ \mu\text{F}$, $L=0.5\text{mH}$. An R - L type load is selected with $R=1\text{k}\ \Omega$, $L=500\text{mH}$, for the first range of simulation. The frequency of the PWM switching signal is chosen as 10 kHz.

First, a set of discrete input voltage is selected over a wide range of 160 volt to 350 volt. The system automatically selects the value of gain and accordingly calculates the value of control voltage v_{dc} . This control voltage modulates the width of pulses applied to two switches $S1$ and $S2$. The set of current and voltage are measured from different runs under different range of input voltages with a fixed load connected. The results are tabulated in Table 1. In the results, it is observed that the variation of output voltage is less than 6 volt only which supports voltage regulation within 2%.

Table 1: The Performance of the voltage regulator under variable input

V_{in} (rms in volts)	I_{in} (rms in amps)	V_{out} (rms in volts)	I_{out} (rms in amps)	Gain (G)	Duty Ratio (D)
160	6.97	234.64	1.17	1.467	0.59
180	6.55	232.37	1.16	1.291	0.56
200	5.86	230.97	1.15	1.155	0.53
220	5.27	230.19	1.15	1.046	0.51
230	5.08	230.04	1.15	1.000	0.50
260	4.73	229.19	1.15	0.882	0.47
290	4.39	228.85	1.14	0.789	0.44
320	3.90	228.71	1.14	0.715	0.42
350	3.90	228.71	1.14	0.654	0.395

Another set of simulation is done under variable load (R - L) conditions with a constant input voltage and Table 2 represents the results of performance for the regulator. For a wide range of variation of load, it is observed output voltage variation again within 2%.

Table 2: Regulator under variable load condition

V_{in} (rms volts)	R (Ω)	L (mH)	V_{out} (rms volts)	I_{out} (rms amp)	I_{in} (rms amp)	Gain
230	200	1000	224.24	0.56	7.26	0.98
	300	500	223.82	0.66	7.40	0.97
230	200	500	221.00	0.86	7.07	0.96
	300	1000	223.42	0.51	7.33	0.97
	400	1000	224.40	0.44	7.48	0.98
	400	500	225.00	0.52	7.59	0.98
	500	500	225.83	0.43	7.67	0.98
	500	1000	225.17	0.38	7.57	0.98
230	1000	1000	228.22	0.22	7.89	0.99
	2000	1000	230.68	0.11	8.23	1.01

For the proposed system, dynamic stability is studied where input source voltage is suddenly varied and its performance is recorded. First, voltage sag is created from 230 volt rms to 160 volt rms and is applied momentarily to

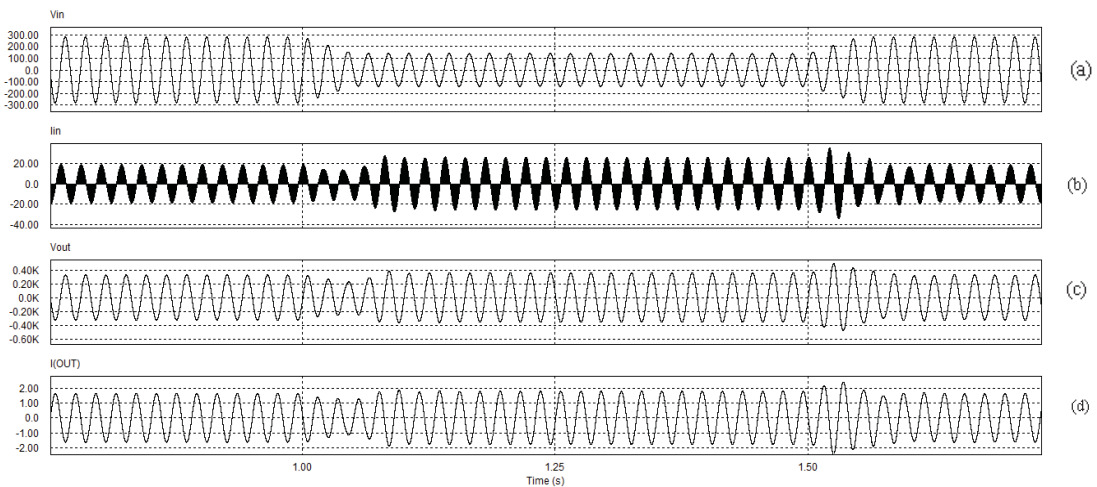

Fig.5: Waveforms during input voltage sag condition (a) Source voltage (b) Source current (c) Output voltage (d) Output current

the system at running condition. In a second stage, a voltage surge is applied suddenly from 230 volt rms to 350 volt rms. In both the cases the output voltage waveforms are recorded and it shows a steady value except some small transients during change over instants in both the cases.

contain the input and output current waveforms. The output currents in both the cases contain a little high frequency harmonics, the total harmonic distortion (THD) of which is measured around 0.1%.

The buck-boost capability of the above-mentioned circuit

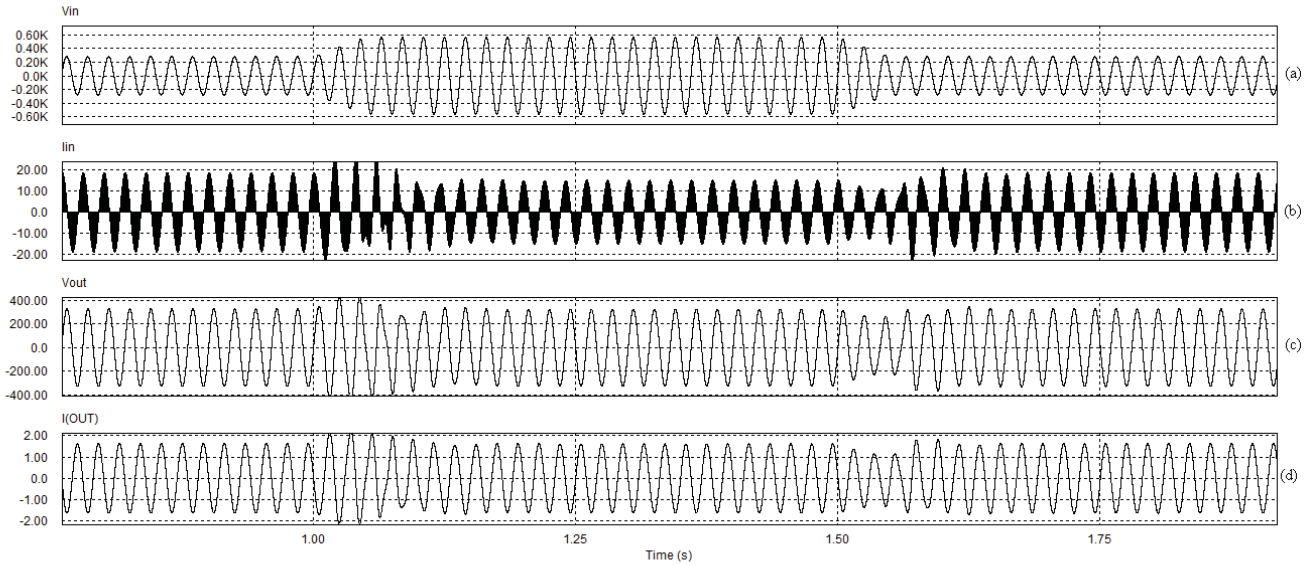
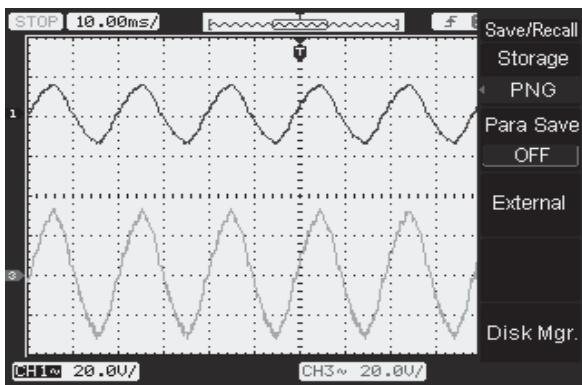
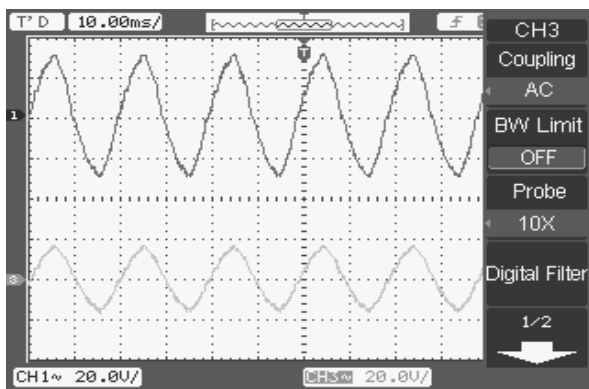

Fig.6: Waveforms during input voltage surge condition (a) Source voltage (b) Source current (c) Output voltage (d) Output current



(a)



(b)

Fig.7: Experimental waveforms for source voltage and load output voltage for (a) Boost condition (b) Buck condition

The two set of results separately shown in fig. 5 and 6 also

is also observed in hardware, developed in the laboratory. Experimental results presented in Fig. 7(a) and 7(b) show source voltage and output voltage waveforms during both boost and buck conditions respectively. The waveforms are captured in 1:10 scaled down conditions.

IV. CONCLUSION

A new ac single-phase voltage regulator based on a simple LC network and employing a simple closed-loop feed-forward control is presented. The proposed single-phase ac-ac converter can keep the output voltage steady by operating both in buck and boost modes. It has the capability to overcome sudden voltage sag or voltage surge in the power line. The results show that this ac-ac converter performs well during the voltage fluctuation and therefore can be used as power conditioner. Operating principle, steady-state and transient analysis of the system was presented. To verify the proposed system, the simulations were implemented to compensate voltage variation about 200 volt in steady state as well as voltage sag and surge in transient condition. Experimental results have been shown to verify the buck and boost capabilities of the proposed regulator. The regulator has some other major advantages like same phase of source and output voltages, no need of additional filtering across the load and of course the low harmonics in the source current. The inherent quick response of the system will allow rural power users, with critical loads, to better withstand the variable voltage conditions and can provide more reliable and quality power. Some instantaneous overshoot are observed in the results of dynamic characteristics and suitable modification in the control system using PID controller is required to reduce it. The system also can be

extended for a three phase ac-ac converter as well as with non-linear load in future.

REFERENCES

- [1] W. L. Congwei, B. Wu, N.R.,Zargari., Xu, Dewei and J. Wang, "A novel three phase three-leg AC/AC converter using nine IGBTs", *IEEE Trans. Power Electronics*, vol. 24, no. 5, pp. 1151–1160, 2009.
- [2] T. Wijekoon, C. Klumpner, P. Zanchetta, and P.W. Wheeler, "Implementation of a hybrid ac–ac direct power converter with unity voltage transfer ratio", *IEEE Trans. Power Electronics*, vol. 23, no. 4, pp. 1918–1926, 2008.
- [3] W. Fei, R. Burgos, P. Yunqing., D. Boroyevich., W. Bingsen., T.A., Lipo., V. D. Immanuel, and K.J. Karimi, "A systematic topology evaluation methodology for high-density three-phase PWM ac–ac converters", *IEEE Trans. Power Electronics*, vol. 23, no.6, pp. 2665–80, 2008.
- [4] R. Vargas, U. Ammann and J. Rodriguez, "Predictive approach to increase efficiency and reduce switching losses onmatrix converters", *IEEE Trans. Power Electronics*, vol. 24, no. 4, pp. 894–902, 2009.
- [5] P. C. Loh, R. Rong, F. Blaabjerg and P. Wang, "Digital carrier modulation and sampling issues of matrix converters", *IEEE Trans. Power Electronics*, vol. 24, no. 7, pp. 1690–1700, 2009.
- [6] X. P. Fang, Z. M. Qian, F. Z. Peng, "Single-phase Z-source PWM ac–ac converters", *IEEE Power Electronics Letter*, vol. 3, no. 4, pp. 121–124, 2005.
- [7] Y. Tang ,C. Zhang and S. Xie, "Z-source ac–ac converters solving commutation problem", *IEEE Trans. Power Electronics*, vol. 22, no. 6, pp. 2146–2154, 2007.
- [8] Z. Fedyczak, R. Strzelecki, and G. Benysek, "Single-phase PWM AC/AC Semiconductor Transformer Topologies and Applications", *Proceedings -IEEE 33rd Annual Power Electronics Specialists Conference, Cairns, Qld., Australia*, vol.2, pp.1048-1053, 2002.

BIOGRAPHIES



Santosh Sonar, born in 1979, received the Graduation and Master Degree in Electrical Engineering from National Institute of Technology Durgapur, India in 2004 and 2009 respectively. From 2004 to 2005, he was a Site Engineer with Test Metal Engineering Pvt Ltd, India. He has more than three years of academic experience. Currently pursuing PhD from Indian School of Mines Dhanbad, India.



Tannoy Maity, born in 1969, received Graduation and Master Degree in Electrical Engineering from Calcutta University and Ph.D from Bengal Engineering & Science University, Sibpore. He has six years industrial and more than thirteen years academic experience. He is currently working as faculty in Indian School of Mines, Dhanbad, India.