

# Maximum Output Power Analysis of Isolated Bidirectional Dual Full Bridge DC-DC Converter with Phase-shift Control Methods

K. Wu<sup>1</sup> W. G. Dunford<sup>1</sup> C. W. de Silva<sup>2</sup>

**Abstract**—This paper analyzes the maximum output power of the bidirectional dual full bridge DC-DC converter with single phase-shift control and dual phase-shift control methods and discusses whether it can be used as an effective standard to evaluate different control methods for a project. The maximum output power is solved with mathematical method and simulation method. However, the conclusions about maximum output power derived with mathematical method are contradictory to those got with power electronics simulation method. This contradictory phenomenon is discussed in detail. It is proved that the mathematical conclusions about this problem are not correct. The actual maximum output power is determined by power circuit configuration, elements parameters and control methods together. Maximum output power should not be used as a standard to evaluate different control methods because it means over-load operation capability. In the end, an effective method is proposed about how to choose a suitable inductance value for a bidirectional converter so that the bidirectional converter can transfer energy with high efficiency in large load scope.

**Keywords**—Bidirectional isolated DC-DC converter, phase-shift control, maximum output power, power circuit configuration, operation of bidirectional converter, output power expression, suitable inductance value.

## I. INTRODUCTION

In recent years, the development of high power and large power range isolated bidirectional dc-dc converters has become an important topic because of the requirements of electric automobile, uninterruptible power supply and aviation power system [2], [3], [4] [13]. This project is to design a forward 1kW/200V and backward 250W/48V bidirectional converter. The dual active full bridge converter is symmetry in both sides of the isolation transformer. It is suitable to be used as the power circuit to transfer energy back and forth, especially for high power case [10]. Therefore, it is chosen as the power circuit for this project. There is one series inductor---  $L_{O1}$  in Fig. 1. This inductor is mainly used to transfer energy between two voltage sources of  $V_S$  and  $V_O$ , enlarge ZVS scope, eliminate the switching loss and ensure the converter have high efficiency in large load scope.

There are several existing control methods for this power circuit, like single phase-shift control [3], dual phase-shift

control [4] and phase-shift plus PWM control [9]. Phase-shift will change for different output powers in phase-shift control methods. It can be realized with a lead-lag compensator [6], [8]. The energy is controlled to transfer back and forth with the phase-shift controller. In practical application, it is very important to choose a suitable control method for the power circuit so that the bidirectional converter can transfer the required power with high efficiency. In order to choose a suitable control method for a project, an effective standard should be used to evaluate different control methods.

Because the bidirectional converter with phase-shift control is a very complicated nonlinear system affected by several factors, the mathematical method is not always correct to solve the maximum output power. Sometimes, contradictory results will be got for these questions with mathematical method and actual situation. This paper will analyze these questions in detail. This is very meaningful for the bidirectional converter design. This problem will be described in detail in Section II; the maximum output power of a bidirectional converter with phase-shift control methods when a serial inductor is in the primary side of the transformer will be analyzed and validated with corresponding simulation results in Section III; the maximum output power of a bidirectional converter with phase-shift control methods when a serial inductor is in the secondary side of the transformer will be analyzed and validated with corresponding simulation results in Section IV; the operation and the general output power expression are analyzed in Section V; the method about how to choose the suitable inductance to make the bidirectional converter realize ZVS and transfer energy with high efficiency in the desired large load scope is proposed in Section VI and the main contributions of this paper is summarized in Section VII.

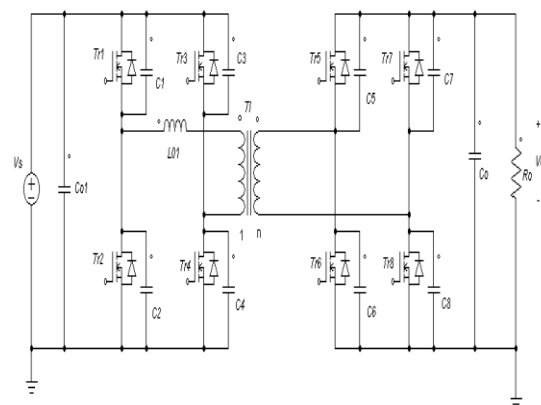

Fig. 1: Power circuit of the bidirectional converter with serial inductor in the primary side of the transformer

The paper first received 31 Oct 2011 and in revised form 22 Apr 2013.

Digital Ref: APEJ-2013-07-113

<sup>1</sup> Department of Electrical and Computer Engineering, The University of British Columbia, Vancouver, BC, V6T 1Z4, Canada

<sup>2</sup> Department of Mechanical Engineering, The University of British Columbia, Vancouver, BC, V6T 1Z4, Canada

E-mail: wukuiyuan2010@hotmail.com

## II. PROBLEM DESCRIPTION

### A. Statement of the Problem

The problem is to make clear the actual maximum output power of the bidirectional converter by only changing the phase-shifts with a given inductance and to discuss whether the maximum output power can be used as an effective standard to evaluate different control methods for a project or not. In order to solve these problems theoretically, mathematical method and simulation method are used to analyze the maximum output power of bidirectional dual full bridge converter with single phase-shift control and dual phase-shift control. Contradictory conclusions are got with these two methods for the same bidirectional converter. It is important to know how to choose a suitable control method for a bidirectional converter with an effective standard so that it can satisfy the specifications very well. Besides these, it is very important to know how to choose a suitable inductance value for the bidirectional converter so that it can realize zero voltage switching (ZVS) and transfer energy with high efficiency in desired load scope.

Although this problem is very difficult and complex, it can be validated by simulation results and practical application analysis is important to know that the eligible minimum inductance should be used for the bidirectional converter if this inductor can make converter realize ZVS and transfer energy with high efficiency in desired load scope. In practical application, the bidirectional converter can only be used to transfer rated power or less. Over-load is not permitted because over-load will damage the product. For a given rated power, the method to determine the required minimum inductance will be much more meaningful than the method which can only provide maximum inductance value. According to these considerations, it will be possible to determine which method is meaningful and should be used in practical bidirectional converter design.

### B. Components in Power Circuits

$L_{01}, L_s$  --- Two series inductors

$C1=C2=C3=C4=C5=C6=C7=C8$  --- Eight snubber capacitors

$C_o, C_{o1}$  --- Two large filter capacitors

$R_o$  --- Forward load resistor

The parameters of the main transformer are as follows:

$L_{p1}$  --- Primary leakage inductance

$L_{s1}$  --- Secondary leakage inductance

Turns ratio: 1: n

The parameters of the eight power MOSFETs are as follows:

$R1, R2, R3, R4, R5, R6, R7, R8$  --- On resistance

$D1, D2, D3, D4, D5, D6, D7, D8$  --- Anti-parallel diodes with power MOSFETs.

### C. Variables Used in This Paper

$i_{ap}, i_{as}$  --- Power circuit primary current and secondary current of the transformer

$V_{c1}, V_{c2}, V_{c3}, V_{c4}, V_{c5}, V_{c6}, V_{c7}, V_{c8}$  --- Control signals for corresponding power switches.

$V_s$  --- Input voltage

$V_o$  --- Output voltage

$V_L$  --- Inductor voltage

K.Wu et al: Maximum Output Power Analysis of Isolated ...

$V_{mn}$  --- Primary voltage of the transformer

$V_{tr2}$  --- Secondary voltage of the transformer

$P_{out}$  --- Average output power of the bidirectional converter

$P_{in}$  --- Average input power of the bidirectional converter

$\varphi$  --- Phase-shift angle (radian)

$D1, D2$  --- Phase-shift duty ratio

## III. MAXIMUM OUTPUT POWER OF BIDIRECTIONAL DUAL FULL BRIDGE CONVERTER WITH PHASE-SHIFT CONTROL METHODS WHEN A SERIAL INDUCTOR IS IN THE PRIMARY SIDE OF THE TRANSFORMER

### 1. The Mathematical Phase-shift Limits and Maximum Output Power with Single Phase-shift Control Method

Because the single phase-shift control is simple and convenient, it is widely used in bidirectional converter. The power transfer formula of the bidirectional dual full bridge converter with single phase-shift control is as following [3]:

$$P_o = \frac{V_s V_o}{\omega L} \left( \varphi - \frac{\varphi^2}{\pi} \right) \quad (1)$$

where  $\omega=2\pi f$  is the switching angular frequency of the full bridge converter and  $L$  is the sum of transformer leakage inductance and that of the serial inductors on both sides of the transformer [3]. According to the above formula, it can be found that the phase-shift  $\varphi$  is equal to zero when the output power is equal to zero. By derivative the power formula, it can be found that the converter (inductor) can transfer maximum power at  $\varphi=\pi/2$  when the values of  $L, V_s, V_o$  and  $f$  are fixed; the maximum power is equal to:

$$P_{o\max} = \frac{\pi \cdot V_s \cdot V_o}{4\omega L} \quad (2)$$

For this situation,  $V_s = 48V, V_o = 200V, L=L_{01}+L_{p1}+L_{s1} = 6.9\mu H + 0.6\mu H + 1\mu H = 8.5\mu H, f=25kHz$ ; with this formula, the maximum output power is equal to:  $P_{o\max} = 5.64kW$ . The detailed power switch and diode models used in the circuit for simulation are listed as follows:

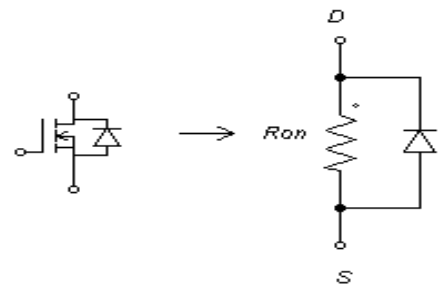

Fig.2: Equivalent circuit of power MOSFET

The parameters of the 8 power switches are as following:  $Tr1 \sim Tr4$ : On resistance: 5m $\Omega$ ; Diode Voltage drop: 1V.  $Tr5 \sim Tr8$ : On resistance: 23m $\Omega$ ; Diode Voltage drop: 0.6V. Here, the parameters of 8 power switches are selected by checking the data sheet of power MOSFET according to the specifications of this project.

### 2. Simulation Studies and Discussion of the Maximum Output Power with Single Phase-shift Control

The simulation waveforms for the bidirectional converter with

single phase-shift control for  $P_o=1kW$  are as following:

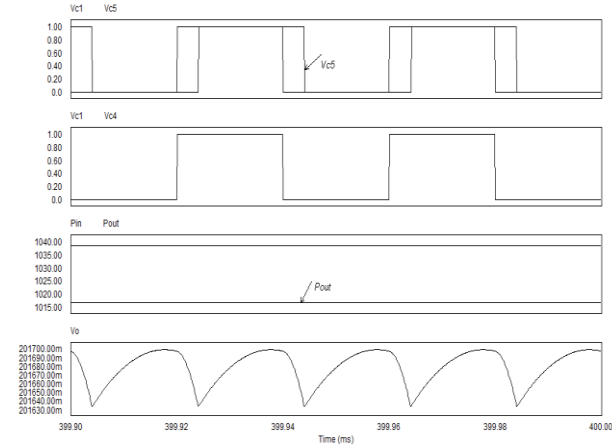

Fig.3: Simulation results of forward converter with single phase-shift control for  $P_o=1kW$

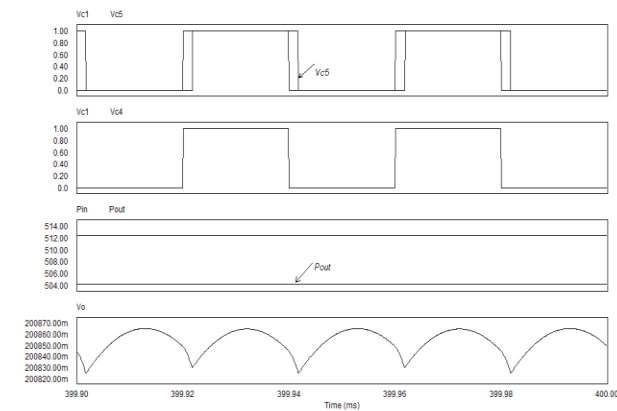

Fig.4: Simulation wave forms of the forward bidirectional converter with single phase-shift control for  $P_o=500W$

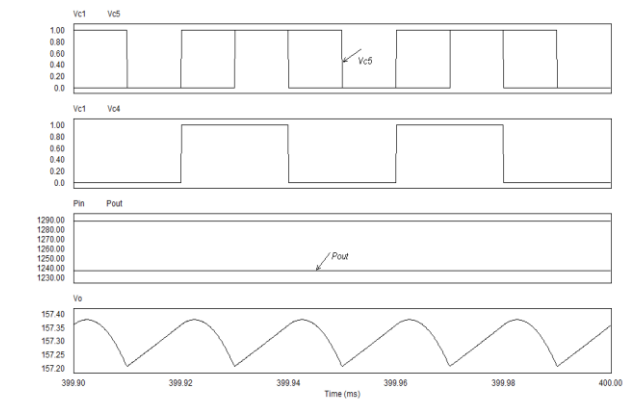

Fig.5: Simulation wave forms of the forward bidirectional converter with single phase-shift control for  $P_o=2kW$

Compare Fig. 3 and Fig. 4, it can be found this bidirectional converter with single phase-shift control can transfer rated output power (1kW) or less by changing the phase-shift value. According to the mathematical maximum output power formula (2), this converter can transfer maximum output power equal to 5.64kW by changing the phase-shift to  $\pi/2$  when the values of  $L$ ,  $V_s$ ,  $V_o$  and  $f$  are fixed. In practice, the bidirectional converter cannot transfer this maximum power no matter how the

phase-shift is changed. This can be seen clearly from the following simulation results.

It can be found this converter cannot transfer output power (2kW) by single phase-shift change only. The output voltage will be always lower than rated value (200V) no matter how the phase-shift value is regulated and the actual maximum output power approximately equal to 1.2kW for this situation. Obviously, it will be impossible to transfer 5.64kW output power by changing the phase-shift only.

### 3. Simulation Studies and Discussion of the Maximum Output Power with Dual Phase-shift Control

What is the actual result of this bidirectional power circuit with dual phase-shift control? This can be seen from the following simulation results for this power circuit with dual phase-shift control.

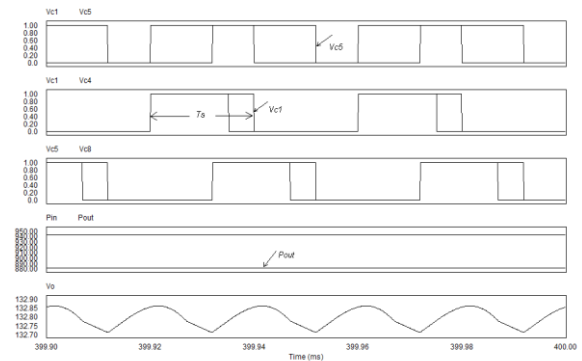

Fig.6: Simulation wave forms of the forward bidirectional converter with dual phase-shift control for  $P_o=2kW$

It can be found this converter cannot transfer output power (2kW) by dual phase-shift control. The output voltage will be always lower than the rated value (200V) and the actual maximum output power approximately equal to 881W. It can be found the actual output power for this power circuit with dual phase-shift control is less than that with single phase-shift control method. It cannot transfer mathematical maximum output power for high conversion ratio ( $M=V_o/V_i = 200/48=4.16>1$ ).

### 4. Simulation Studies and Discussion of the Maximum Output Power with Single Phase-shift Control for Low Conversion Ratio ( $M=V_o/V_i = 48/200=0.24<1$ )

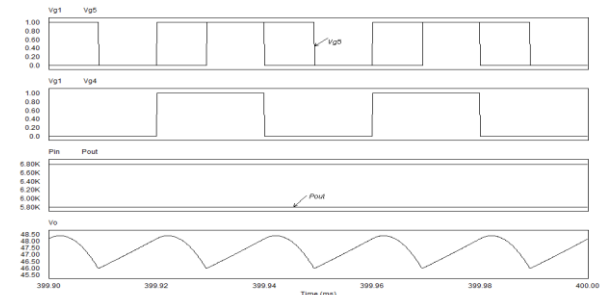

Fig.7: Simulation wave forms of the forward bidirectional converter with single phase-shift control for  $P_o=5.9kW$

It can be found that the output power in this situation is equal to 5.8kW. It is greater than the calculated maximum output power 5.64kW. It can be found the maximum output power will be different with different conversion

ratio and turns ratio, too.

Obviously, these are contradictory to the conclusion got by mathematical method. (1) is not correct. The mathematical maximum output power is meaningless because this will make the converter over-load. Over-load is not permitted in practical application. Over-load application will damage the product.

#### IV. MAXIMUM OUTPUT POWER OF BIDIRECTIONAL DUAL FULL BRIDGE CONVERTER WITH PHASE-SHIFT CONTROL METHODS WHEN A SERIAL INDUCTOR IS IN THE SECONDARY SIDE OF THE TRANSFORMER

##### 1. The Mathematical Maximum Output Power with Dual Phase-shift Control Method

There are two control variables in dual phase-shift control, the first phase-shift  $D_1$  between primary control signal and corresponding secondary control signal, the second phase-shift  $D_2$  between diagonal control signals; this will make the energy transfer more flexibly and more effectively than single phase-shift control. Please see the definition of phase-shifts  $D_1$ ,  $D_2$  and period  $T_s$  in Fig. 9. It is suitable to be used in bidirectional dual full bridge converter. The power circuit for this situation is shown in Fig. 8. The power transfer formula of the bidirectional dual full bridge converter with dual phase-shift control is as following [4]: The PSpice software is numerical simulation program for electronic circuits and therefore actual component values are required to be specified. Thus the simulator gives particular solution of the defined circuit. The results of the particular solution need to be normalized to suitable base values to extract the generalized results for comparison. In the circuit description proposed in the following paragraphs, the resonant network can be described in terms of global variables or parameters. We need not to specify actual component values. Normalized results are directly obtained from the simulation.

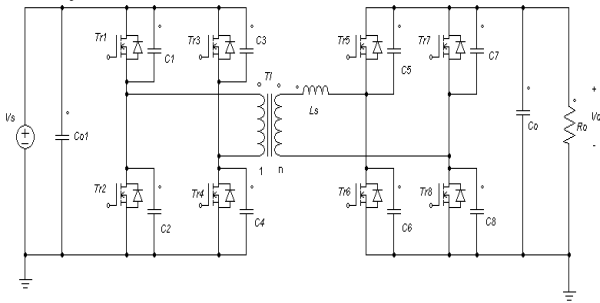

Fig. 8: Power circuit of the bidirectional converter with serial inductor in the secondary side of the transformer

when  $D_1 \leq 1/2$ , the expression of the output power is:

$$P = \frac{\pi \cdot V_s \cdot V_o}{2f_s L_s} \cdot \begin{cases} D_2(2-2D_1-D_2), & 0 \leq D_2 \leq D_1 \\ D_2(1-D_1-D_2) + D_1 - D_1^2, & D_1 \leq D_2 \leq 1-D_1 \\ (1-D_1)(1-D_2), & 1-D_1 \leq D_2 \leq 1 \end{cases} \quad (3)$$

when  $D_1 > 1/2$ , the expression of the output power is:

$$P = \frac{\pi \cdot V_s \cdot V_o}{2f_s L_s}$$

$$\begin{cases} D_2(2-2D_1-D_2), & 0 \leq D_2 \leq 1-D_1 \\ (1-D_1)^2, & 1-D_1 \leq D_2 \leq D_1 \\ (1-D_1)(1-D_2), & D_1 \leq D_2 \leq 1 \end{cases} \quad (4)$$

The global maximum power is at ( $D_1=1/3$ ,  $D_2=1/3$ ) via the partial derivatives of output power expressions (4) and (5). The maximum output power is 4/3 times of that with single phase-shift control. When the values of  $L$ ,  $V_s$ ,  $V_o$  and  $f$  are fixed; the maximum power of the bidirectional converter with dual phase-shift control is equal to:

$$P_{o \max} = \frac{\pi V_s V_o}{3\omega L} \quad (5)$$

This is because the general output power formula is the same no matter where the serial inductor is placed in primary side or in secondary side of the transformer [3]. For this project,  $L_s=L_{01}=6.9 \mu\text{H}$ , other parameters are the same as those in Fig.1; the mathematical maximum output power of this bidirectional converter with single phase-shift control is equal to 5.64kW. Therefore, the mathematical maximum output power of this bidirectional converter with dual phase-shift control is equal to 7.52kW. It can transfer this output power by changing these two phase-shifts values when other parameters are fixed.

##### 2. Simulation Studies and Discussion of the Maximum Output Power with Dual Phase-shift Control

In order to make clear whether the results got by mathematical method is correct or not, the simulation results of the bidirectional converter with dual phase-shift control for different output powers are listed as follows:

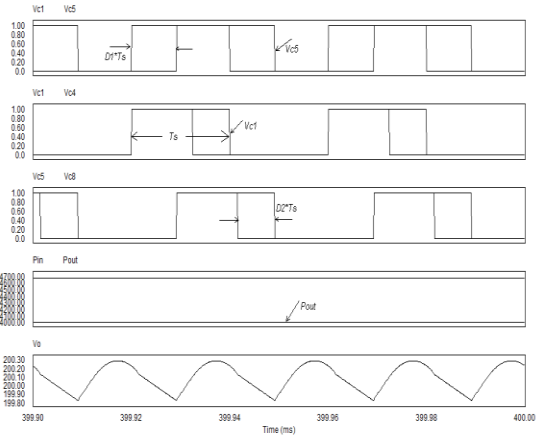

Fig.9: Simulation wave forms of the forward bidirectional converter with dual phase-shift control for  $P_o=4\text{kW}$

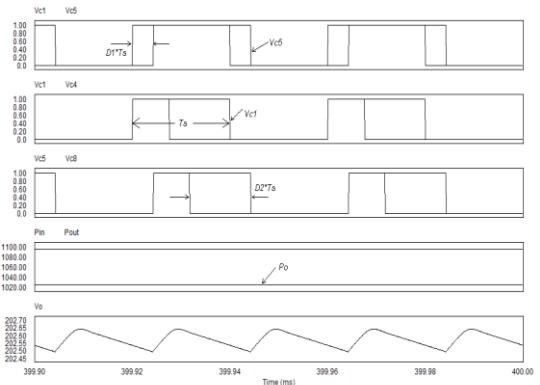

Fig.10: Simulation wave forms of the forward bidirectional converter with dual phase-shift control for  $P_o=1\text{kW}$

By comparing these simulation results listed above, it can be found clearly the phase-shift  $D_1$  will increase as the increase of the output power; the phase-shift  $D_2$  will decrease as the increase of the output power. In Fig.9, it can be found that efficiency is equal to 85.6% when the output power is equal to 4kW. In Fig.10, it can be found that efficiency is equal to 93.7% when the output power is equal to 1kW. Therefore, the efficiency will reduce obviously with the increase of the output power only by regulating the phase-shifts. It is meaningless to do so in practical application.

Besides this, it can be found the mathematical conclusion about the maximum output power of the bidirectional converter with dual phase-shift control is not correct. Although dual phase-shifts  $D1$  and  $D2$  can vary in the large range, the bidirectional converter cannot transfer the maximum output power by regulating the dual phase-shifts only when other parameters are fixed for a specified rated output power bidirectional converter. This can be validated by the following simulation results which expect to transfer 5kW output power by changing dual phase-shifts with this bidirectional converter.

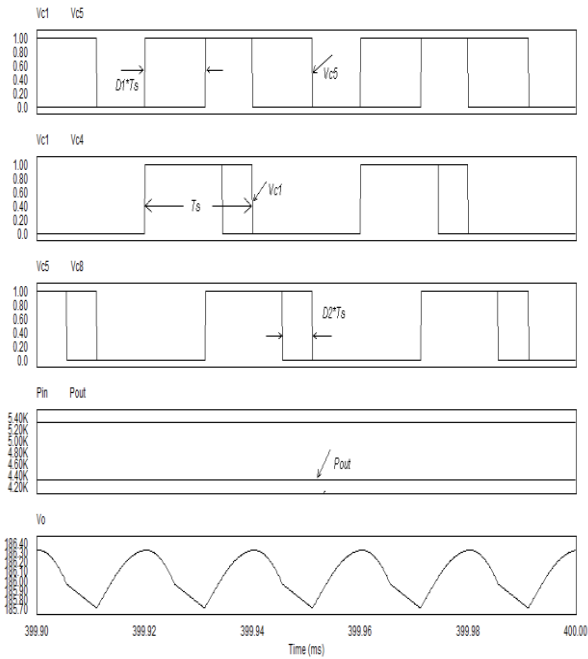

Fig.11: Simulation wave forms of the forward bidirectional converter with dual phase-shift control for  $P_o=5kW$

These simulation results suggest this bidirectional converter cannot transfer 5kW output power by changing dual phase-shifts only. For the expected 5kW output power situation, the bidirectional converter cannot transfer actual output power higher than 4.3kW no matter how the dual phase-shifts are regulated. The efficiency for this case is only equal to 81.3%. These results prove that the mathematical conclusion about the maximum output power is not correct.

### 3. Simulation Studies and Discussion of the Maximum Output Power with Single Phase-shift Control

What is the result of this bidirectional power circuit with single phase-shift control? The simulation results of this

power circuit with single phase-shift control are attached in the follows.

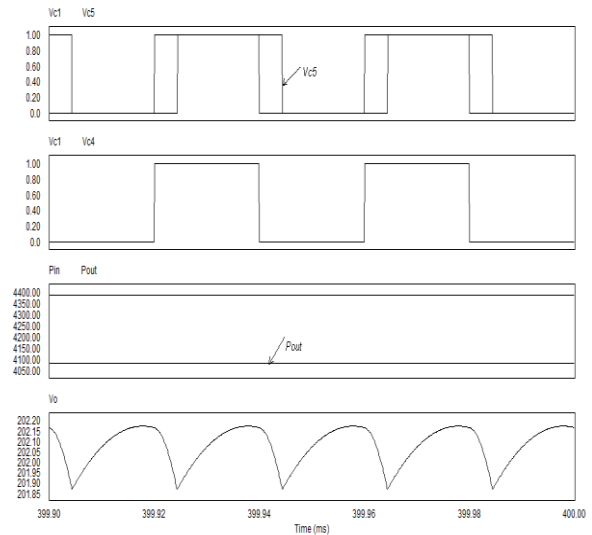

Fig.12: Simulation wave forms of the forward bidirectional converter with single phase-shift control for  $P_o=4kW$

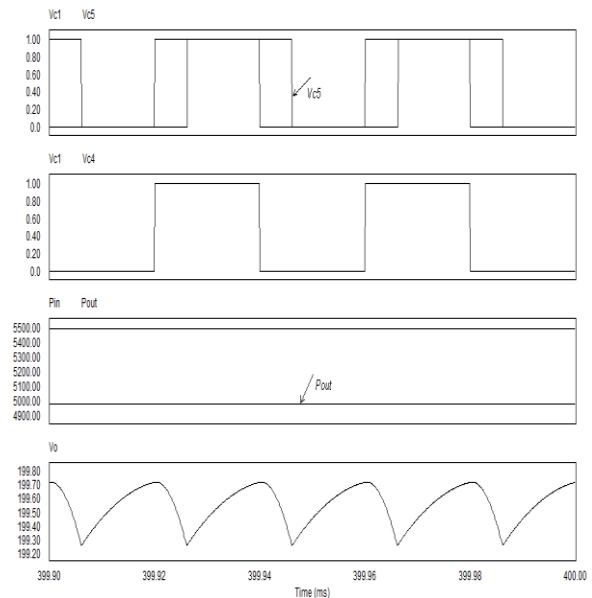

Fig.13: Simulation wave forms of the forward bidirectional converter with single phase-shift control for  $P_o=5kW$

In Fig.12, it can be found that efficiency is equal to 93.1% when the output power of this bidirectional power circuit with single phase-shift control is equal to 4kW. It is higher than 85.6% for 4kW output power when dual phase-shift control is used.

In Fig.13, it can be found that efficiency is equal to 90.6% when the output power of this bidirectional power circuit with single phase-shift control is equal to 5kW.

In Fig.14, it can be found that efficiency is equal to 86.9% when the output power of this bidirectional power circuit with single phase-shift control is equal to 5.5kW. Obviously, it is higher than the actual maximum output power of 4.3kW for the same power circuit with dual phase-shift control. It cannot transfer 5.64kW maximum output power no matter how the phase-shift value is

regulated. This suggests both the mathematical conclusion that the maximum output power with dual phase-shift control is equal to 4/3 times of the maximum output power with single phase-shift control and the mathematical conclusion of maximum output power with single phase-shift control are not correct. The actual maximum output power when the serial inductor is put in the primary side of the transformer is different from that when the serial inductor is put in the secondary side of the transformer. The inductance on both sides of transformer cannot add directly. Therefore, (1) is wrong.

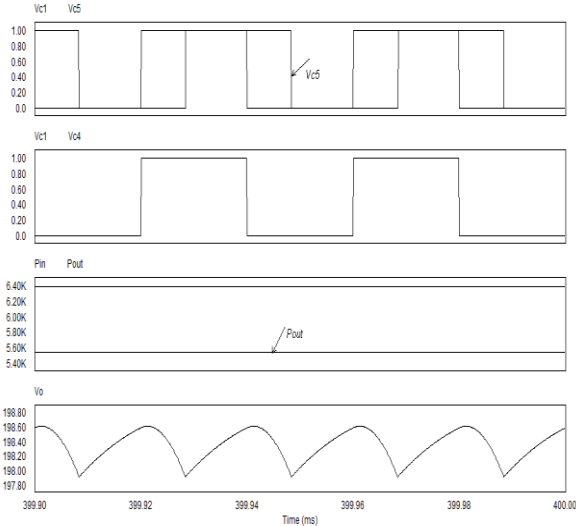

Fig.14: Simulation wave forms of the forward bidirectional converter with single phase-shift control for  $P_o=5.64kW$

4. Simulation Studies and Discussion of the Maximum Output Power with Single Phase-shift Control for Low Conversion Ratio ( $M=V_o/V_i = 48/200=0.24<1$ )

From the following Fig.15, it can be found the maximum output power will be different with different conversion ratio and turns ratio for this situation, too.

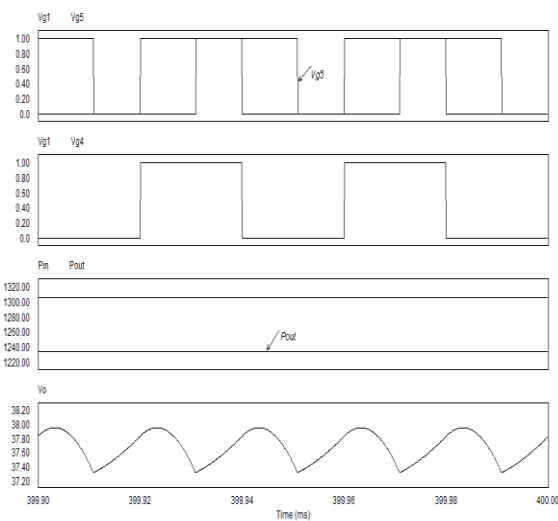

Fig.15: Simulation wave forms of the forward bidirectional converter with single phase-shift control for  $P_o=2kW$

It can be found this converter cannot transfer output power (2kW) by single phase-shift change only in this situation.

The output voltage will be always lower than rated value (48V) no matter how the phase-shift value is regulated and the actual maximum output power approximately equal to 1.24kW for this situation. Obviously, it is different from the maximum output power for high conversion ratio ( $M=V_o/V_i=200/48=4.16$ ). This proves that (1) is wrong again.

Maximum output power should not be a standard to evaluate different control methods of a bidirectional converter because maximum output power will cause over-load operation. Over-load operation is not permitted in practical application because it will damage the product. A meaningful standard to compare different control methods should be whether it can make bidirectional converter transfer rated output power or less with high efficiency and high output voltage stability under parameter change. A bidirectional converter can transfer higher output power easily with high efficiency by reducing the inductance and adjusting control circuit parameters.

V. OPERATION AND OUTPUT POWER EXPRESSION OF THE BIDIRECTIONAL CONVERTER WITH SINGLE PHASE-SHIFT CONTROL

In order to analyze the operation and get the general output power expression of the bidirectional converter with single phase-shift control method, the general power circuit is shown in Fig.16. Generally, the loss of the power converter includes conduction loss and switching loss [5], [15]. For the high frequency converter, switching loss is a very important factor to influence efficiency [17], [7], [14]. In order to eliminate switching loss, zero-voltage switching (ZVS) or zero-current-switching (ZCS) technology is used in the power circuit [1], [16], [18].

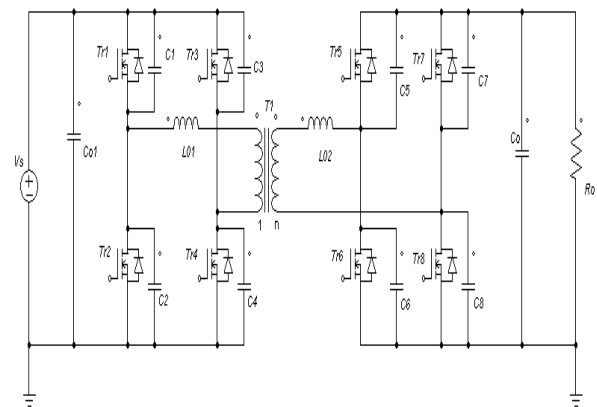

Fig.16: The power circuit of the bidirectional converter

The forward simulation wave-forms of the bidirectional converter with normal steady state operation are as shown in Fig. 17.

It is seen that this single phase-shift control method includes one phase-shift. It is the phase-shift between the primary control signal and the corresponding secondary control signal, for example, between  $V_{g1}$  and  $V_{g5}$ . The forward bidirectional dual full bridge converter is separated into six stages in one period. Its operation and equivalent circuit for every stage are described next.

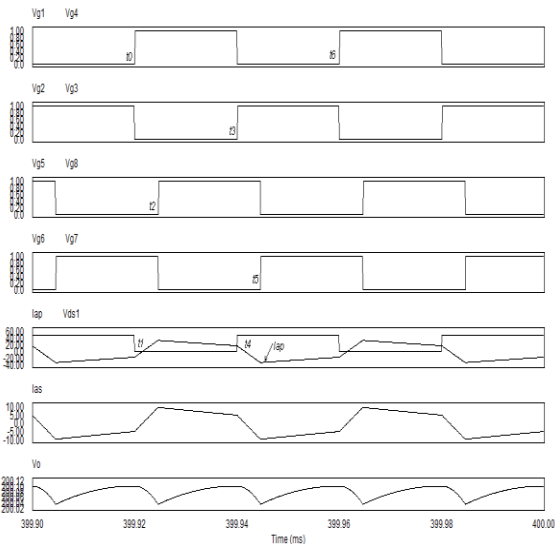

Fig.17: Simulation waveforms of the forward bidirectional converter with single phase-shift control

**A. Stage 1 ( $t_0 \sim t_1$ )**

Power switches  $Tr1$  and  $Tr4$  will turn on at “ $t=t_0$ .” Because the primary current is still negative during this stage, the inductor energy flows back to the power source. The primary current will flow through  $Tr4/Tr1$ . This is because the voltage drop across the on-resistance of the power MOSFET when it conducts is lower than the required conduction voltage drop of anti-parallel diode. Normally, the diode will not conduct.

Because  $Vg5/Vg8$  are all equal to zero,  $Tr5/Tr8$  are all in the “Off” state.  $Vg6/Vg7=1$  and  $Tr6/Tr7$  are in “On” state. Also  $ias < 0$  and the secondary current flows through  $Tr6/Tr7$ . The inductor  $L02$  and output capacitor provide energy to the load. The output voltage reduces during this stage.

**B. Stage 2 ( $t_1 \sim t_2$ )**

Power switches  $Tr1$  and  $Tr4$  will turn on in this stage. Because the primary current is positive during this stage, the primary source energy transfers to the primary inductor and the secondary side. The primary current will flow through  $Tr1/Tr4$ .

Because  $Vg5/Vg8$  are all equal to zero,  $Tr5/Tr8$  are all in the “Off” state.  $Vg6/Vg7=1$  and  $Tr6/Tr7$  are in the “On” state. Also  $ias > 0$  and the secondary current flows through  $Tr6/Tr7$ . The inductor  $L02$  and output capacitor provide energy to the load. The output voltage reduces during this stage.

**C. Stage 3 ( $t_2 \sim t_3$ )**

Because  $Vg1/Vg4 = 1$ , power switches  $Tr1$  and  $Tr4$  are in “On” state in this stage. Because the primary current is positive during this stage, it will flow through  $Tr1/Tr4$ , the inductor  $L01$  and the transformer leakage inductance. The energy will transfer from the primary side to the secondary side.

For the secondary side,  $Tr6/Tr7$  turn off a little before  $t_2$ . Because  $ias > 0$ , the secondary current will charge capacitor

$C6/C7$  and discharge capacitor  $C5/C8$  until their voltages reduce to the forward conduction voltage of diode  $D5/D8$ . Then the current flows through  $D5/D8$ . The energy is transferred to the load. The output voltage begins to increase in this sub-stage.

The control signals  $Vg5/Vg8=1$  at  $t_2$ , power switches  $Tr5/Tr8$  will turn on at  $t_2$ . Because  $ias > 0$  during this stage, the secondary side current will flow through  $Tr5/Tr8$  and transfer energy to the load. The output voltage will increase in this stage.

**D. Stage 4 ( $t_3 \sim t_4$ )**

For the primary side,  $Tr1/Tr4$  turn off a little before  $t_3$ . Because  $iap > 0$ , the primary current will charge capacitor  $C1/C4$  and discharge capacitor  $C2/C3$  until their voltages reduce to the forward conduction voltage of diode  $D2/D3$ . Then the current flows through  $D2/D3$ . The energy is transferred to the primary source. Because  $Vg2/Vg3=1$  at  $t_3$ ,  $Tr2/Tr3$  will turn on at  $t_3$  under ZVS. Because the primary current  $iap > 0$ , the energy will feed back to the primary source in this stage.

Because  $Vg5/Vg8=1$ ,  $Tr5/Tr8$  are all in the “On” state.  $Vg6/Vg7=0$  and  $Tr6/Tr7$  are in “Off” state. Also  $ias > 0$  and the secondary current flows through  $Tr5/Tr8$  to the load. The output voltage increases during this stage. According to this analysis, the equivalent circuits in this stage can be obtained similarly.

**E. Stage 5 ( $t_4 \sim t_5$ )**

Power switches  $Tr2$  and  $Tr3$  will turn on in this stage. Because the primary current is negative during this stage, the primary source energy transfers to the primary inductor and the secondary side. The primary current will flow through  $Tr2/Tr3$ .

Because  $Vg5/Vg8 = 1$ ,  $Tr5/Tr8$  are all in the “On” state.  $Vg6/Vg7=0$  and  $Tr6/Tr7$  are in the “Off” state. Also  $ias < 0$  and the secondary current flows through  $Tr5/Tr8$ . The output capacitor provides energy to the load. The output voltage reduces during this stage. According to this analysis, the equivalent circuits in this stage can be obtained similarly.

**F. Stage 6 ( $t_5 \sim t_6$ )**

Because  $Vg2/Vg3=1$ ,  $Tr2/Tr3$  will be on in this stage. Because the primary current  $iap < 0$ , the energy will transfer to the secondary side again.

For the secondary side,  $Tr5/Tr8$  turn off a little before  $t_5$ . Because  $ias < 0$ , the secondary current will charge capacitor  $C5/C8$  and discharge capacitor  $C6/C7$  until their voltages reduce to the forward conduction voltage of diode  $D6/D7$ . Then the current flows through  $D6/D7$ . The energy is transferred to the load.

Because  $Vg6/Vg7=1$  at  $t_5$ ,  $Tr6/Tr7$  will turn on at  $t_5$  under ZVS. The output voltage begins to increase during this stage. According to this analysis, the equivalent circuits in this stage can be obtained similarly.

**G. The Expression of Voltage Ratio  $Vo/Vs$**

In order to see clearly the major role of triple phase-shift

control method, the power MOSFETs and diodes are treated as ideal and the winding resistance of the transformer is neglected. From the working process analysis and the simulation waveforms shown in Fig.17, it can be found that the inductor current  $i_{ap}$  crosses zero at the half period of  $T_s$ . The first stage ( $t_0\sim t_1$ ) and the fourth stage ( $t_3\sim t_4$ ) are due to the dead band effect. They are neglected as well. In order to be convenient, write:

$$L_{eq} = L_{01} + L_p + \frac{1}{n^2}L_{02} + \frac{1}{n^2}L_s$$

Because the time interval in which the snubber capacitors charge/discharge is very short compared with the stage time duration, it can be neglected, too. From Fig.17, it can be found the corresponding stages are equal to:

$$t_2 - t_0 = DT_s$$

$$t_3 - t_2 = (0.5 - D)T_s$$

$D$  is the phase-shift duty ratio. Apply Volt-second balance and small ripple approximation to the combined equivalent inductor  $L_{eq}$ , there is:

$$(V_s + \frac{V_0}{n})D + (-\frac{V_o}{n} + V_s)(0.5 - D) = 0 \quad (6)$$

The relationship between the output voltage and source voltage can be obtained from (6) and written as:

$$\frac{V_o}{V_s} = \frac{n}{(1-4D)} \quad (7)$$

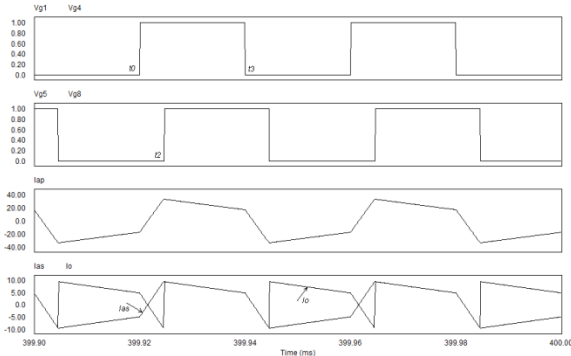

Fig.18: Waveforms of relevant currents and control signals of bidirectional converter with single phase-shift control

Compared Fig. 18 with Fig.17, it can be found there are two main stages and two corresponding current expressions in the first half period. In ideal situation, currents  $i_{ap}$ ,  $i_{as}$  and  $i_o$  will vary from zero at  $t=t_0$  and return to zero at  $t=t_3$ . The current expressions in ZVS sub-stages need not to be considered because the time for ZVS sub-stages are very short and there is no active power transfer in ZVS sub-stages theoretically.

#### H. The Expression of Output Current in Stage $t_0\sim t_2$

According to the operation in this stage, the ideal state equations are:

$$\begin{aligned} L_{eq} \frac{di_{ap}}{dt} &= V_s + \frac{V_o}{n} \\ i_{as} &= \frac{i_{ap}}{n} \\ i_o &= -i_{as} \end{aligned} \quad (8)$$

From these state equations, the expression of output

current in this stage can be solved as following:

$$i_o = -\frac{2V_s(1-2D)t}{\pi L_{eq}(1-4D)} \quad (9)$$

#### I. The Expression of Output Current in Stage $t_2\sim t_3$

According to the operation in this stage, the ideal state equations are:

$$\begin{aligned} L_{eq} \frac{di_{ap}}{dt} &= V_s - \frac{V_o}{n} \\ i_{as} &= \frac{i_{ap}}{n} \\ i_o &= i_{as} \end{aligned} \quad (10)$$

From these state equations, the expression of output current in this stage can be solved as following:

$$i_o = \frac{2V_s(1-2D)DT_s}{nL_{eq}(1-4D)} - \frac{4DV_s t}{nL_{eq}(1-4D)} \quad (11)$$

#### J. The Expression of Output Power

The output current expressions in the second half period are the same as the corresponding expressions listed above. Therefore, the expression of output power with single phase-shift control is:

$$P_o = \frac{2}{T_s} \int_0^{T_s} V_o i_o dt = \frac{2V_o}{T_s} \left[ \int_{t_0}^{t_2} i_o dt + \int_{t_2}^{t_3} i_o dt \right] \quad (12)$$

Substitute the corresponding expressions of  $i_o$  into the above equation, the average active output power can be obtained.

$$P_o = \frac{V_o V_s (16D^3 - 10D^2 + D)}{nf_s L_{eq} (1-4D)} \quad (13)$$

From this output power expression, it can be found there is no maximum output power with regard to the phase-shift ratio  $D$  in its valid range ( $0 \leq D \leq 0.5$ ).

This proves the former discussion about the maximum output power of the bidirectional converter with phase-shift control methods is correct.

## VI. METHOD TO DECIDE INDUCTANCE FOR BIDIRECTIONAL DUAL FULL BRIDGE CONVERTER WITH PHASE-SHIFT CONTROL

It is important and meaningful to choose a suitable inductance value for the bidirectional converter so that the converter can transfer the rated output power or less with high efficiency and high output voltage stability. Based on this ZVS dual full bridge power circuit, an effective method about how to choose a suitable inductance value for the bidirectional converter is introduced in this section.

It is well known the minimum inductance should be used to finish the power transfer if it can satisfy the requirements. This will reduce the size of the power converter. The main point is that the total inductance must be able to make the converter realize ZVS under possible minimum output power. Only in this way, can the bidirectional converter transfer energy with high efficiency in large output power range. Otherwise, the power converter cannot realize ZVS in low output power and efficiency will reduce greatly.

Practically, this problem can be solved in this way. At first,



simulate the bidirectional converter with a control method with only the leakage inductance of the isolation transformer for possible minimum output power to check whether this converter can realize ZVS or not. If it cannot realize ZVS with only the transformer leakage inductance, a serial small inductance is required. Include a small serial inductance in the power circuit and simulate the bidirectional converter to check whether the bidirectional converter can realize ZVS or not under the same possible minimum output power. If this bidirectional converter still cannot realize ZVS with this small serial inductor, increase the serial inductance value gradually and simulate the bidirectional converter. Repeat this again and again until a minimum or sub-minimum serial inductance value is found to make the bidirectional converter realize ZVS under possible minimum output power.

The principle to decide the totally required minimum inductance is to ensure the bidirectional converter realize ZVS under possible minimum output power [12], [11]. This is because ZVS is realized by charging and discharging snubber capacitors with the energy stored in the inductors. With the decrease of the output power, the current in power circuit will reduce and the energy stored in the inductor will reduce, too. If the inductance is too small, it cannot provide enough energy for the bidirectional converter to realize ZVS in minimum load condition. This can be validated by the following simulation results of the bidirectional converter with single phase-shift control ( $L_{OI}=0.003\ \mu\text{H}/P_o=500\text{W}$ ;  $L_{OI}=6.9\ \mu\text{H}/P_o=500\text{W}$ ).

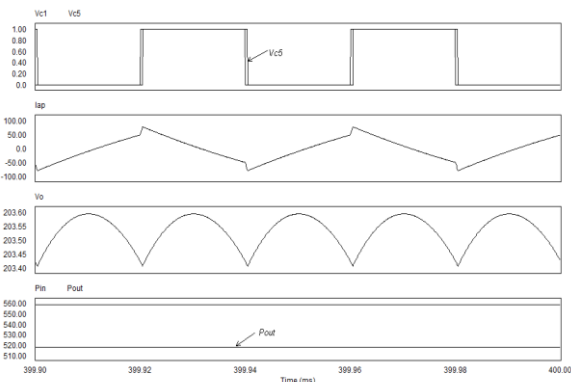

Fig. 19: Simulation wave forms of the forward bidirectional converter with single phase-shift control for  $L_{OI}=0.003\ \mu\text{H}/P_o=500\text{W}$

In Fig. 19, it can be found the primary current  $I_{ap} > 0$  at the rising edge of control signal  $V_{c1}$ , therefore, the bidirectional converter cannot realize ZVS when  $L_{OI}=0.003\ \mu\text{H}$  and  $P_o=500\text{W}$ . In order to realize ZVS, the serial inductance  $L_{OI}$  should be increased.

In Fig. 20, it can be found the primary current  $I_{ap} < 0$  at the rising edge of control signal  $V_{c1}$ , this suggests this bidirectional converter can realize ZVS at present. The switching loss is eliminated and efficiency is improved. Certainly, the converter can realize ZVS better with the same inductance for higher output power if the converter can realize ZVS with this inductance at a lower output power. Therefore, the minimum inductance for the bidirectional converter is the value to make the power

converter realize ZVS under possible minimum output power. This minimum inductance will make the bidirectional converter realize ZVS in the desired load range and transfer energy with high efficiency in this load scope.

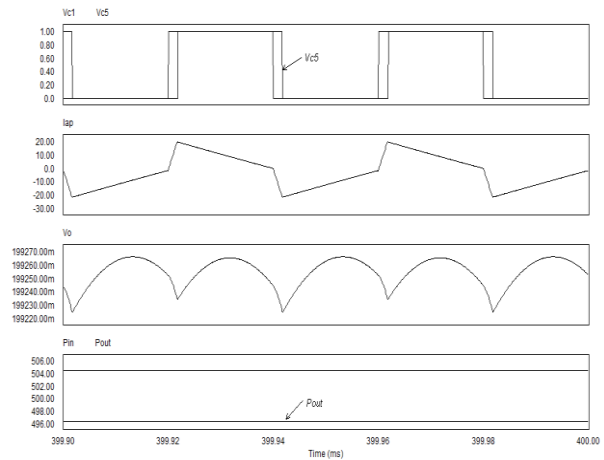

Fig. 20: Simulation wave forms of the forward bidirectional converter with single phase-shift Control for  $L_{OI}=6.9\ \mu\text{H}/P_o=500\text{W}$

## VII. CONCLUSIONS

This paper analyzes the maximum output power of a bidirectional dual full bridge DC-DC converter with single phase-shift control and dual phase-shift control methods in detail. The maximum output power is solved with mathematical method and analyzed with simulation results separately. However, contradictory conclusions are derived for the same bidirectional converter with two different analysis methods. Besides this, the actual maximum output power is relevant to the position of the serial inductor and the voltage conversion ratio. It can be found that maximum output power cannot be used as a standard to evaluate different control methods because it means the over-load operation of the converter. Even if the components rated parameters are permitted, the bidirectional converter cannot transfer this maximum power only by changing the phase-shifts. It is very important to make clear this point for the design of a bidirectional converter. Besides these, the general operation and output power expression of bidirectional converter with single phase-shift control are listed out. In the end, an effective method is proposed about how to choose a suitable inductance for the bidirectional converter to make it realize ZVS and transfer energy with high efficiency in large load scope.

## REFERENCES

- [1] H. Wang, Q. Sun, H.S.H. Chung, S. Tapuchi and A. Ioinovici, "A ZCS Current-Fed Full-Bridge PWM Converter with Self-Adaptable Soft-Switching Snubber Energy", *IEEE Trans. Power Electron.*, vol. 24, no. 8, pp. 1977-1991, Aug. 2009.
- [2] H.J. Chiu and L.W. Lin, "A bidirectional DC-DC converter for fuel cell electric vehicle driving systems," *IEEE Trans. Power Electron.*, vol. 21, no. 4, pp. 950-958, July 2006.
- [3] S. Inoue and H. Akagi, "A Bidirectional DC-DC Converter for an Energy Storage System with Galvanic Isolation",

*IEEE Trans. Power Electron.*, vol. 22, no. 6, November 2007.

- [4] H. Bai and C. Mi, "Eliminate Reactive Power and Increase System Efficiency of Isolated Bidirectional Dual Active Bridge DC-DC Converters Using Novel Dual Phase Shift Control", *IEEE Trans. Power Electron.*, vol. 23, no. 6, November 2008.
- [5] R.W. Erickson, D. Maksimovic, *Fundamentals of Power Electronics (Second Edition)*, Springer Science+Business Media, Inc. 2001.
- [6] G.C. Goodwin, S.F. Graebe, M.E. Salgado, *Control System Design*, Prentice Hall of India, 2006.
- [7] T-J. Tai, K-H. Chen, "Switching Loss Calculation (SLC) and Positive/Negative Slope Compensation Dynamic Droop Scaling (PNC-DDS) Technique for High-Efficiency Multi-Input Single Output (MISO) Systems", *IEEE Trans. Power Electron.*, vol. 24, no. 5, pp.1386-1398, May 2009
- [8] C.W. de Silva, *Modeling and Control of Engineering Systems*, Boca Raton, FL: CRC Press/Taylor & Francis, 2009.
- [9] D.H. Xu, C.H. Zhao and H.F. Fan, "A PWM plus phase-shift control bidirectional DC-DC converter", *IEEE Trans. Power Electron.*, vol. 19, no. 3, pp. 666-675, May 2004.
- [10] L. Zhu, "A novel soft-commutating isolated boost full bridge ZVS-PWM dc-dc converter for bidirectional high power applications", *IEEE Trans. Power Electron.*, vol. 21, no.2, pp. 422-429, March, 2006.
- [11] J.A. Carr, B. Rowden, J.C. Balda, "A Three-Level Full-Bridge Zero-Voltage Zero-Current Switching Converter With a Simplified Switching Scheme", *IEEE Trans. Power Electron.*, vol. 24, no. 2, pp.329-338, Feb. 2009.
- [12] K. Wu and W. G. Dunford, "An Unusual Full Bridge Converter to Realize ZVS in Large Load Scope", *Asian Power Electron. Journal*, vol. 2, no. 1, Apr 2008, pp. 66-71.
- [13] J. Hu, Y. Chen and Z. Yang, "Study and Simulation of One Bidirectional DC-DC Converter in Hybrid Electric Vehicle", *Proceedings of Third International Conference on Power Electronics Systems and Applications*, 2009.
- [14] Y. Xiong, S. Sun, H. Jia, P. Shea and Z.J. Shen, "New Physical Insights on Power MOSFET Switching Losses", *IEEE Trans. Power Electron.*, vol. 24, no. 2, pp.525-531, Feb. 2009.
- [15] S. Inoue and H. Akagi, "Loss Analysis of a bidirectional isolated dc/dc converter", *Proc. Int. Power Electron. Conf. (IPEC)*, 2005.
- [16] P. Das, B. Laan, S.A. Mousavi and G. Moschopoulos, "A Nonisolated Bidirectional ZVS-PWM Active Clamped DC-DC Converter", *IEEE Trans. Power Electron.*, vol. 24, no. 2, pp.553-558, Feb. 2009.
- [17] R. Vargas, U. Ammann and J. Rodriguez, "Predictive Approach to Increase Efficiency and Reduce Switching Losses on Matrix Converters", *IEEE Trans. Power Electron.*, vol. 24, no. 4, pp.894-902, April 2009.
- [18] E. Adib and H. Farzanehfard, "Zero-Voltage Transition Current-Fed Full-Bridge PWM Converter", *IEEE Trans. Power Electron.*, vol. 24, no. 4, pp.1041-1047, April 2009.

#### BIOGRAPHIES



**Kuiyuan Wu** received the B.S. degree from Southwest Jiao Tong University, China (1990); M.S. degrees from Chinese Academy of Sciences, Beijing, China (1997); and University of British Columbia, Canada (2008); and PhD degree from University of British Columbia, Vancouver, Canada (2012), all in electrical engineering. From 2009 to 2010, he was with Alpha Technologies Ltd. His current research interests include the

combination of power electronics with advanced control theory, novel control method and novel power converter development, especially isolated bidirectional DC-DC converters, active power factor correctors,

high power ZVS power supplies and high frequency inverter type resistance welding machines.



**William G. Dunford** received the B.S. and M.S. degrees from Imperial College, London, U.K. and the Ph.D. degree from the University of Toronto, Toronto, ON, Canada, all in electrical engineering. He has also been a faculty member of both institutions and is currently a faculty and Senate member of the University of British Columbia, Vancouver, BC, Canada. His industrial experience includes positions at the Royal Aircraft Establishment (now Qinetiq), Schlumberger and Alcatel. He has had a long term interest in photovoltaic powered systems and is also involved in projects in the automotive and distributed systems areas.

Dr. Dunford has served in various positions on the Advisory Committee of the IEEE Power Electronics Society and chaired PESC in 1986 and 2001.



**Clarence W. de Silva** is a Fellow of: ASME, IEEE, Canadian Academy of Engineering, and Royal Society of Canada, and a distinguished Visiting Fellow of the Royal Academy of Engineering. He received Ph.D. degrees from Massachusetts Institute of Technology (1978); and University of Cambridge, U.K. (1998); and honorary D.Eng. degree from University of Waterloo, Canada (2008). A Professor of

Mechanical Engineering and NSERC-BC Packers Chair holder in Industrial Automation, at the University of British Columbia, Vancouver, Canada since 1988, he currently occupies the Tier 1 Canada Research Chair in Mechatronics & Industrial Automation. He has authored 20 books and over 400 papers, approximately half of which are in journals. His recent books published by Taylor & Francis/CRC are: *Mechatronics—A Foundation Course* (2010); *Modeling and Control of Engineering Systems* (2009); *Sensors and Actuators—Control System Instrumentation* (2007); *VIBRATION—Fundamentals and Practice, 2<sup>nd</sup> Ed.* (2007); *Mechatronics—An Integrated Approach* (2005); and by Addison Wesley: *Computing and Intelligent Systems Design—Theory, Tools, and Applications* (with F. Karray, 2004).