

Boundary Control of a Buck Converter with Second-Order Switching Surface and Conventional PID Control- A Comparative Study

P. Kumar¹

Abstract—This paper presents a comparative study of boundary control of a buck converter with second-order switching surface and conventional PID control. Fixed frequency boundary control technique is based on the concept of integrating variable hysteresis and second-order switching surface incorporated into boundary control technique. PID control is a very popular conventional technique which gives linear control for the buck converter. Both the control methods have been implemented for a 140W, 24V/12V buck converter. The basic operating principles and stability analysis, design parameters will be given for both the controllers. The steady state characteristics, output voltage ripple and efficiency of the converter will be discussed under very large disturbances like change in input voltages and output loads. Simulink model of each individual parts like second-order boundary control, Frequency to voltage converter, hysteresis band has been given. The system responses under large signal supply voltage and load disturbances have been verified by MATLAB/SIMULINK.

Keywords—PID control, second-order boundary control, buck converter, Matlab/simulink.

I. INTRODUCTION

Controlling a switched power converter resembles a wide area of research in control technology. Most of the electronic devices operate at some input supply usually constant in nature. With the increase in circuit complexity and improved technology a more severe requirement for accurate and fast regulation is desired. This has led to need for a newer and more reliable design of controllers which can have faster response with better performance. In general a dc-dc converter inputs are unregulated dc voltage input and outputs a constant or regulated voltage.

A boundary control technique builds on a state-space representation of a converter's operation. In state space, the vector of inductor currents and capacitor voltages evolves over time and subsequent points form a system trajectory. When switch action is made dependant on the state, the control law can be represented as a switching surface [1]. Boundary control is a large-signal tool for the design and analysis of switching power converters. A boundary control splits the state space of a given converter with a switching surface, such that on one side of the boundary, the converter operation is governed by on-state trajectories and on the other side off-state trajectories are followed [2], [3]. Boundary control techniques with linear switching surfaces, such as hysteresis control and sliding-mode control [1], [2], [4], or nonlinear switching surfaces to pulse width-modulated control strategies in dc/dc

switching regulators. It addresses the complete operation of a converter and does not differentiate startup, transient, and steady-state periods[1], [10].

Several commonly used methods for reducing of switching frequency of static power converters are coupled to a sliding mode controller. Sliding mode control methods have been used earlier to operate power converter at its finite switching frequency, but it also results some error as control system operates at finite switching frequency[11], [12]. Similarly, pulse modulation based sliding mode control can also be used to operate converter at its fixed frequency[13]. Two novel approaches adopting the sliding mode concept can be used to make the system tracking reference inputs. Phase currents and the neutral point voltage are controlled simultaneously[14].

As we know, the error increases as the converter's switching frequency decreases as the same integral sliding mode control becomes ineffective in reducing the steady state error which has been earlier used to suppress the steady state error through incorporating additional integral term of state variable into the controller [15]. The ripple control is the simplest among all switching regulators. Main advantages of the ripple regulator, like other variable frequency regulators, are fast transient response, unconditional stability, and wide range of output/input voltages. But the switching frequency depends on the operating conditions and power filter [16].

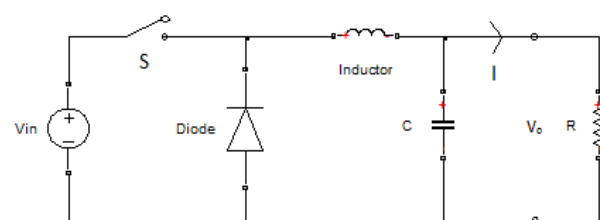

Fig. 1: Buck converter topology

II. BUCK CONVERTER MODELING

In Fig.1 a dc-dc buck converter is shown. The buck converter circuit converts a higher dc input voltage to lower dc output voltage. It consists of a controlled switch S , an uncontrolled switch D (diode), an inductor L , a capacitor C , and a load resistance R . In the description of converter operation, it is assumed that all the components are ideal and also the converter operates in CCM. In CCM operation, the inductor current flows continuously over one switching period. When the switch S is ON and diode D is reverse biased, the dynamics of inductor current I_L and the capacitor voltage V_C are

The paper first received 20 June 2014 and in revised form 17 Nov 2014.

Digital Ref: APEJ-2014-6-442

¹ Department of Electrical Engineering, Indian Institute of Technology (BHU)

E-mail: piyushkumar.nitw@gmail.com

$$\frac{dI_L}{dt} = \frac{1}{L}(V_{in} - V_o) \text{ and } \frac{dV_o}{dt} = \frac{dV_c}{dt} = \frac{1}{C}I_c \quad (1)$$

when the switch S is off and D is forward biased, the dynamics of the circuit are

$$\frac{dI_L}{dt} = -\frac{1}{L}V_o \text{ and } \frac{dV_o}{dt} = \frac{dV_c}{dt} = \frac{1}{C}I_c \quad (2)$$

Table 1: Buck converter design parameters

Parameters	Values
L	100 μH
R	1.2/2.4 ohm
C	400 μF
V_{in}	20-30V

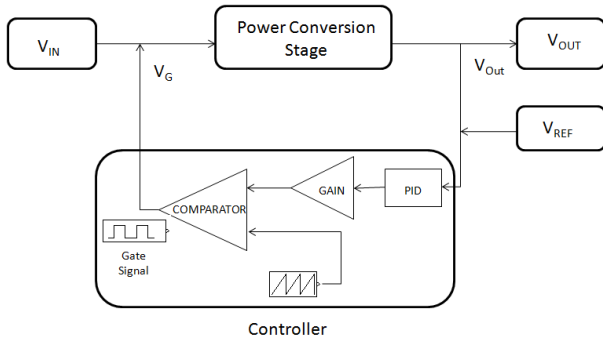

Fig. 2: System block diagram for PID controller

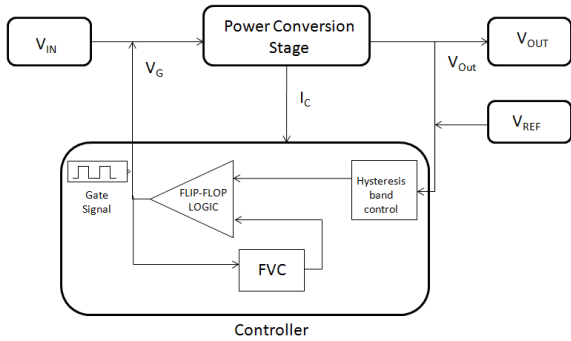

Fig. 3: System block diagram for SBC controller

III. CONTROL TECHNIQUES

Fig. 2 and Fig. 3 shows the part-wise system block diagram for the implementation of PID and SBC controllers during buck converter application respectively.

A. Second-order boundary control implementation

It consists of four major parts, including the main power conversion stage (PCS), the second-order boundary controller (SBC) [5]–[7], the frequency-to-voltage converter (FVC), and the error amplifier (EA).

FVC firstly converts the gate signal V_G for PCS into a dc voltage V_{FVC} , which will then be compared with a reference voltage $V_{f,ref}$ by EA. The output of EA, Δ , is used to control the hysteresis band. SBC inside will generate upper and lower bands together with Δ to determine the switching times of the main switch S in PCS. Thus, the function of SBC is used to regulate the output voltage and the earlier mentioned four parts form a feedback loop for regulating the switching frequency [9].

B. Frequency to voltage converter

In Fig. 4 simulink model of FVC is shown. FVC presence helps in operating the system at its fixed frequency. It generates the necessary voltage which is proportional to the frequency. It governs the system to operate close to its fixed frequency by detecting the change in δV_f which will be in proportion to δf_s .

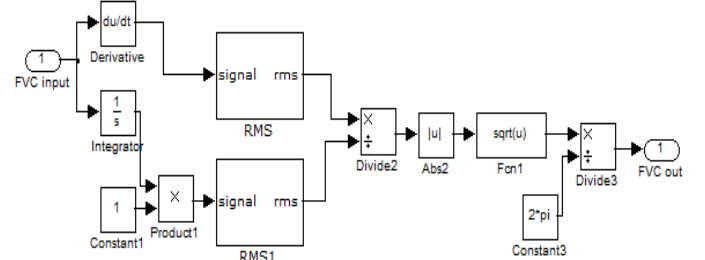

Fig. 4: Frequency to voltage converter model

C. PID controller

The PID controller involves three separate constant parameters the proportional, the integral and derivative values, denoted by P, I, and D. Control signal of PID controller is denoted by

$$u(t) = ke(t) + \int_0^t k_i(\tau) d\tau + k_d \frac{\partial e(t)}{\partial t} \quad (3)$$

Control parameters assumed for PID control implementation are $K_p=1.26$, $K_i=0.003$ and $K_d=2.23$ respectively.

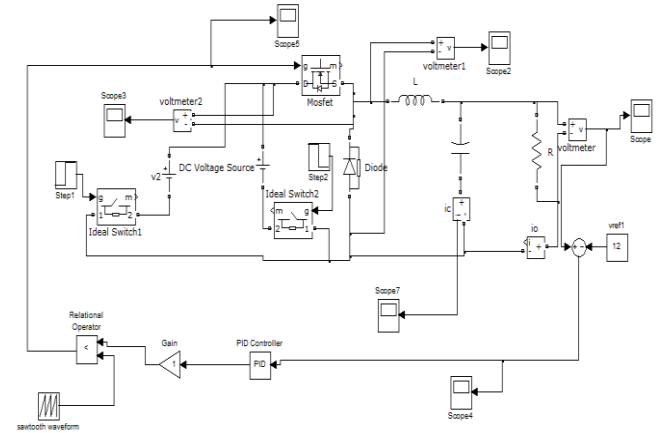

Fig. 5: Matlab/Simulink implementation of a PID controller

IV. SIMULATION RESULT VERIFICATION

140 W buck converter has been tested with both control techniques and the specifications are given as follows:

- input voltage, V_{in} : 20–30V
- output voltage, V_o : 12V
- maximum output voltage ripple, 2 V
- maximum inductor current ripple: 7 A

Fig. 5 and Fig. 6 show the simulink model implementation of PID controller and SBC controller respectively. Fig. 7 to Fig. 10 show the waveforms of the output voltage and the load current when the input voltage is changed suddenly from 20V to 30V and vice versa, respectively. As observed in the waveform, the maximum and minimum output voltage ripple obtained with PID are 12.68V and 11.04V respectively while with SBC the maximum and

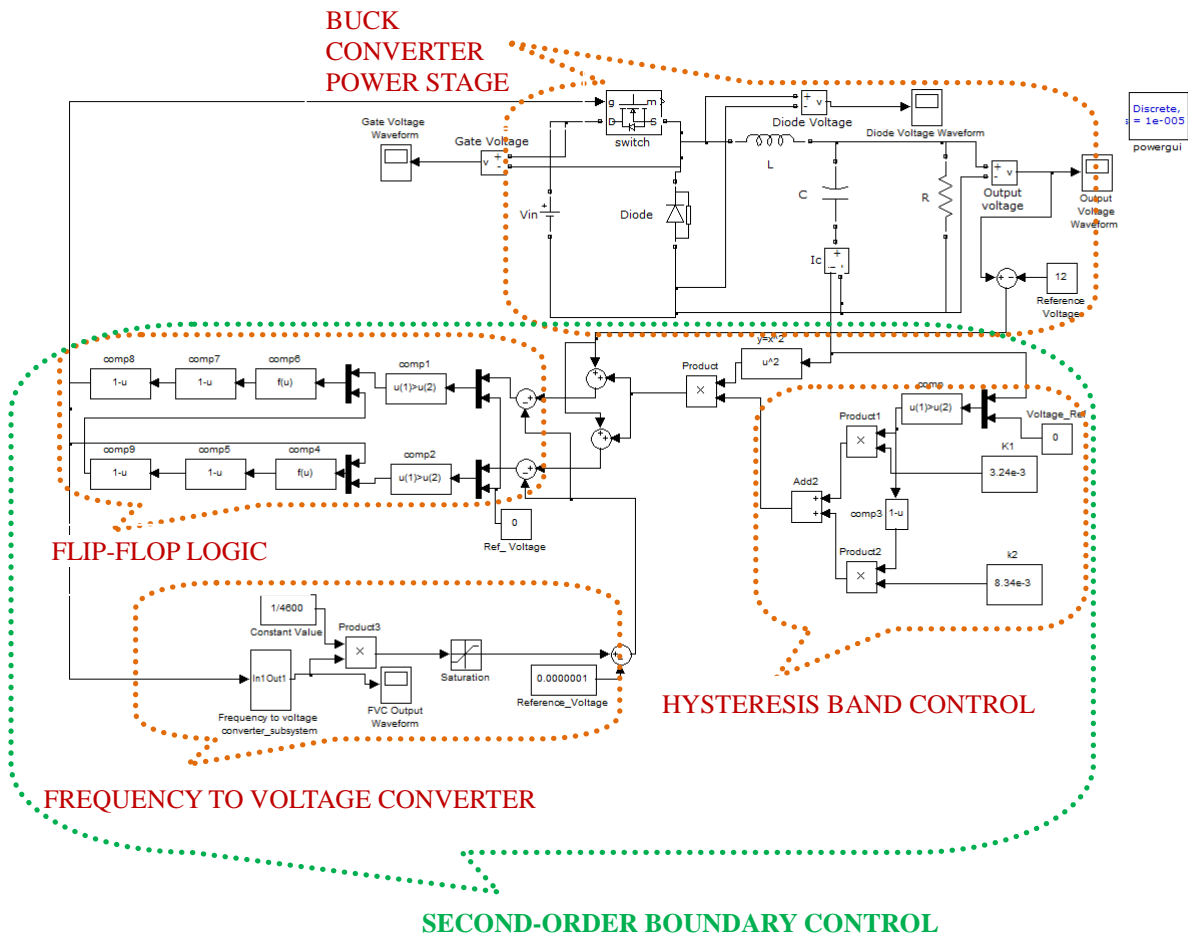

Fig. 6: Matlab/Simulink implementation of second-order boundary (SBC) control of a Buck converter

minimum output voltage ripple obtained are 12.02V and 11.96V respectively. Therefore, there is overall 96.3% improvement in the output voltage ripple after the occurrence of disturbance with SBC control algorithm. Similarly, there is a 95.6% improvement in load current ripple with the use of SBC.

Fig. 11 to Fig. 14 show the waveforms when the load resistance change from 1.2 Ω (10A, 120W) to 2.4 Ω (5A, 60W), and vice versa, respectively.

For better understanding, the maximum and minimum voltage and load current obtained under all possible disturbance considered are duly tabulated in Table-II. With the use of PID controller there is a large fluctuation in output voltage and load current ripple during and after disturbances, whereas SBC controller keeps current and voltage ripple almost constant throughout during and after the disturbance.

For SBC control, the transient periods last about 40 μs and 50 μs. Again, the converter settles in two switching actions and the steady-state switching period is also kept at about 40 μs before and after the two input disturbances. The input voltage is introduced with a high percentage of ripples.

Apart from studying the dynamic response, it can be observed that the output voltage can be regulated tightly at the steady state without being affected by the input

voltage ripple. Whereas PID control takes more time to settle showing more ripple content during all type of transient period.

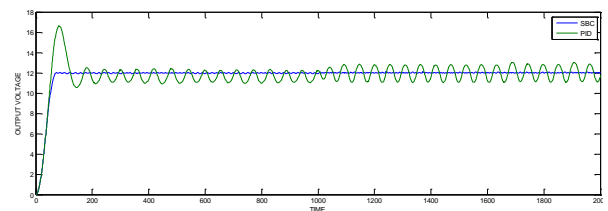

Fig. 7: Sudden change in input V_i from 30V to 20V

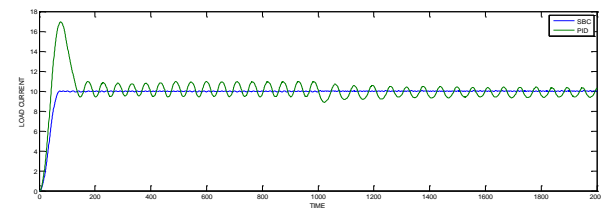

Fig. 8: Sudden change in input V_i from 30V to 20V

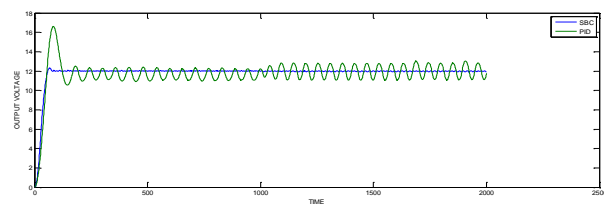

Fig. 9: Sudden change in input V_i from 20V to 30V

Table 11: Comparative results index in terms of output ripple for SBC and PID control implemented in a buck before and after disturbance

Quantity changed	Parameters	Ripple Δ	Output ripple with PID		Output ripple with SBC	
			before	after	before	after
Input voltage (30V to 20V)	Output voltage	Maximum	12.24	12.82	12.04	12.04
		Minimum	11.08	11.1	11.95	11.94
	Load current	Maximum	10.25	10.68	10.07	10.07
		Minimum	9.163	9.226	9.93	9.93
Input voltage (20V to 30V)	Output voltage	Maximum	13.15	12.68	12.02	12.02
		Minimum	11.34	11.04	11.95	11.96
	Load current	Maximum	10.96	10.57	10.04	10.02
		Minimum	9.448	9.19	9.993	9.96
Load 2.4Ω (5A, 60W) to 1.2Ω (10A, 120W)	Output voltage	Maximum	12.33	12.67	12.03	12.02
		Minimum	11.73	11.27	11.94	11.97
	Load current	Maximum	5.16	10.58	5.013	10.02
		Minimum	4.89	9.25	4.98	9.95
Load 1.2Ω (10A, 120W) to 2.4Ω(5A, 60W)	Output voltage	Maximum	12.67	12.36	12.03	12.06
		Minimum	11.17	11.69	11.98	11.97
	Load current	Maximum	10.55	5.13	10.03	5.02
		Minimum	9.28	4.86	9.93	4.97

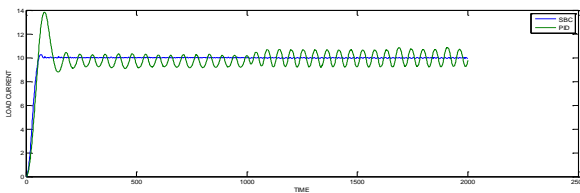

Fig. 10: Sudden change in input V_i from 20V to 30V

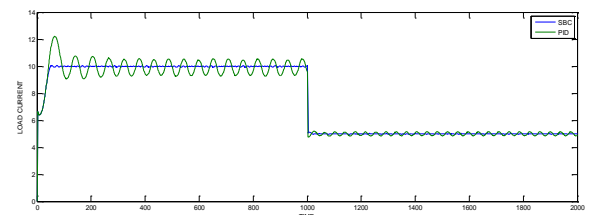

Fig. 14: Sudden load change from 1.2Ω (10A,120W) to 2.4Ω (5A, 60W)

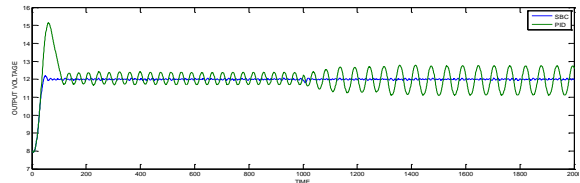

Fig. 11: Sudden load change from 2.4Ω (5A, 60W) to 1.2Ω (10A, 120W)

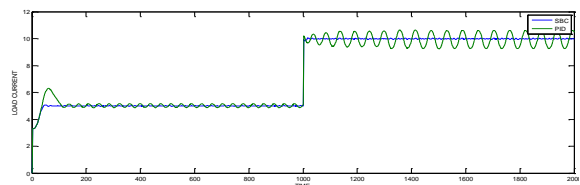

Fig. 12: Sudden load change from 2.4Ω (5A, 60W) to 1.2Ω (10A, 120W)

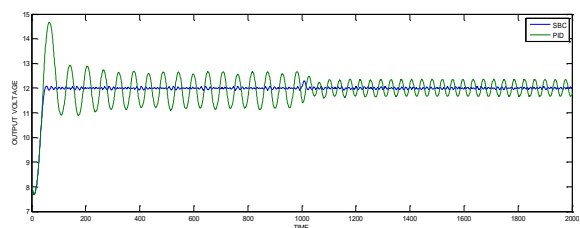

Fig. 13: Sudden load change from 1.2Ω (10A,120W) to 2.4Ω (5A, 60W)

V. CONCLUSION

Boundary control technique with second-order switching surface and PID control technique for buck converters has been presented and compared. Second-order boundary control exhibits two key features. First, the technique combines the advantage of SBC that the converter can reach the steady state in two switching actions after large-signal disturbances. Second, the switching frequency can be kept at a relatively constant value and the implementation of the frequency control loop only requires simple circuitry. A 140 W prototype has been tested. It can be clearly inferred from the output waveform and comparative table that output ripple variation in PID control seems more as compared to SBC control which has almost similar output ripple before and after the occurrence of external disturbances. In PID control output ripple increases as long as load decreases and this makes the system less efficient as compared to SBC control. Overall there is good agreement between the theoretical predictions and simulation results. As the proposed controller gives a wide range of operation over large disturbances, these can be further extended to other converter topologies.

REFERENCES

- [1] R. Munzert, P. T. Krein, M. Carpita, and M. Marchesoni, "Issues in boundary control of power convertors," in PESC Record. 27th Annual IEEE Power Electronics Specialists Conference, vol. 1, no. 5, pp. 810-816, 1996.
- [2] M. Greuel, R. Muysshondt, and P. T. Krein, "Design approaches to boundary controllers," in PESC97. Record 28th Annual IEEE Power Electronics Specialists Conference. Formerly Power Conditioning Specialists Conference 1970-71. Power Processing and Electronic Specialists Conference 1972, vol. 1, pp. 672-678, 1997.
- [3] W. Yan, C. N. Ho, H. S. Chung, and K. T. K. Au, "Fixed-frequency boundary control of buck converter with second-order switching surface," *IEEE Trans. Power Electron.*, vol. 24, no. 9, pp. 2193-2201, Sep. 2009.
- [4] W. T. Yan, H. S. H. Chung, K. T. K. Au, and C. N. M. Ho, "Fixed-frequency boundary control of buck converters with second-order switching surface," in 2008 IEEE Power Electronics Specialists Conference, pp. 629-635, 2008.
- [5] J. Matas, L. Garcia de Vicuna, J. Miret, J. M. Guerrero, and M. Castilla, "Feedback linearization of a single-phase active power filter via sliding mode control," *IEEE Trans. Power Electron.*, vol. 23, no. 1, pp. 116-125, Jan. 2008.
- [6] K. K. S. Leung and H. S. H. Chung, "Derivation of a second-order switching surface in the boundary control of buck converters," *IEEE Power Electron. Lett.*, vol. 2, no. 2, pp. 63-67, Jun. 2004.
- [7] K. S. Leung and H. S. H. Chung, "A comparative study of the boundary control of buck converters using first- and second-order switching surfaces-Part I: continuous conduction mode," in IEEE 36th Conference on Power Electronics Specialists, pp. 2133-2139, 2005.
- [8] M. Ordonez, M. T. Iqbal, and J. E. Quicoe, "Selection of a curved switching surface for buck converters," *IEEE Trans. Power Electron.*, vol. 21, no. 4, pp. 1148-1153, Jul. 2006.
- [9] K. K. Leung and H. S. Chung, "A comparative study of boundary control with first- and second-order switching surfaces for buck converters operating in DCM," *IEEE Trans. Power Electron.*, vol. 22, no. 4, pp. 1196-1209, Jul. 2007.
- [10] S. Banerjee and G. C. Verghese, Nonlinear Phenomena in Power Electronics. IEEE, pp. 472, 2001.
- [11] B. J. Cardoso, A. F. Moreira, B. R. Menezes, and P. C. Cortizo, "Analysis of switching frequency reduction methods applied to sliding mode controlled DC-DC converters," in Proc. APEC '92 Seventh Annual Applied Power Electronics Conference and Exposition, pp. 403-410, 1992.
- [12] M. Carpita and M. Marchesoni, "Experimental study of a power conditioning system using sliding mode control," *IEEE Trans. Power Electron.*, vol. 11, no. 5, pp. 731-742, 1996.
- [13] Y. M. Lai and C. K. Tse, "A unified approach to the design of PWM-based sliding-mode voltage controllers for basic DC-DC converters in continuous conduction mode," *IEEE Trans. Circuits Syst. I Regul. Pap.*, vol. 53, no. 8, pp. 1816-1827, Aug. 2006.
- [14] V. Utkin, "Sliding Mode Pulsewidth Modulation," *IEEE Trans. Power Electron.*, vol. 23, no. 2, pp. 619-626, Mar. 2008.
- [15] Y.M. Lai and C. K. Tse, "Indirect sliding mode control of power Converters via double integral sliding surface," *IEEE Trans. Power Electron.*, vol. 23, no. 2, pp. 600-611, Mar. 2008.
- [16] C-H Tso and J-C Wu, "A ripple control buck regulator with fixed output frequency," *IEEE Power Electron. Lett.*, vol. 99, no. 3, pp. 61-63, Sep. 2003.

ACKNOWLEDGMENT

The author would like to thank Dr. B.K. Murthy (Professor at Department of Electrical Engineering, NIT Warangal) for his esteemed guidance and support during entire duration of the project.

BIOGRAPHY



Piyush Kumar obtained his B.Tech degree in Electrical & Electronics Engineering from SRM University, Chennai in the year 2009 and M.Tech in Power electronics & Drives from National Institute of Technology, Warangal in the year 2011 respectively. He worked briefly as a Graduate Engineering Associate at Central Power Research Institute (CPRI) during the year 2011-2013. Currently he is working as a Senior

Research Fellow under department of Electrical Engineering at Indian Institute of Technology (BHU). He received the two year fellowship by ministry of human resource and development, Govt. of India during two year masters degree. His current research interest include power converter design and control, power electronics application in power systems and renewable energy.